

**User Manual****E-220 Series
Universal Advanced
TFT Display PID Controllers**

Manufacturer / Technical Support
Elimko Electronic Production and Control Co. Ltd.
8. Avenue 68. Street No:16 06510 Emek- Ankara / TÜRKIYE
Phone: + 90 312 212 64 50 Fax: + 90 312 212 41 43
www.elimko.com.tr e-mail:elimko@elimko.com.tr

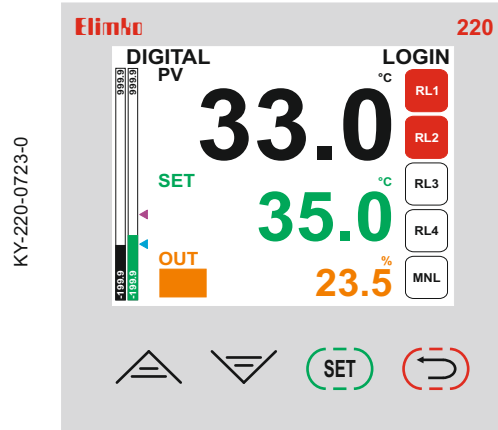

Manufacturer / Technical Support
Elimko Electronic Production and Control Co. Ltd.
8. Avenue 68. Street No:16 06510 Emek- Ankara / TURKEY
Phone: + 90 312 212 64 50 Fax: + 90 312 212 41 43
www.elimko.com.tr e-mail:elimko@elimko.com.tr

Elimko _____ E-220

E-220 series devices are designed as panel mounted instruments for industrial usages.

Package content of E-220 series devices:
Device
2 clamps
Operating manual
Warranty certificate



After opening the package, visually check that the type of the device corresponds to the order and whether the parts listed above are missing or not.

Read the user manual carefully before installing the devices.

Panel mounting, electrical connections and parameter settings of the devices must be done by qualified technicians.

Do not use the equipment in environments where flammable and explosive gases are present. This may cause explosions.

Do not use cleaners containing alcohol, thinner, etc. to clean the devices. Clean the device by wiping with a damp cloth.

Life time of the devices is 10 years.

Compliance with EU Directives

Low Voltage Directive
EN 61010-1

Electromagnetic Compatibility
EN 61326



KY-220-0723-0

TS EN ISO 9001
Quality Management System Certificate

E-220 _____ Elimko**CONTENTS**

1. DEFINITION	2
2. TECHNICAL SPECIFICATIONS	3
2.1. Input Types	4
2.2. Type Coding	5
2.3. Dimensions	6
2.4. Panel Mounting	7
2.5. Connection Diagrams	8
2.6. Front Panel	10
3. USAGE	11
3.1. Device Energization and Start Page	11
3.2. Title Area	11
3.3. LED Indicators and Meanings	13
3.4. Operator Pages	14
3.4.1. ANALOG Operator Page	16
3.4.2. DIGITAL Operator Page	18
3.4.3. ALARM.SET Operator Page	22
3.4.4. STATUS Operator Page	23
3.5. SETTINGS	24
3.5.1. Setting Parameters	26
3.5.2. INPUT Page	29
3.5.3. OUTPUT Page	34
3.5.4. SET Page	49
3.5.5. ALARM Page	51
3.5.6. TUNE Page	54
3.5.7. DEVICE Page	56
3.5.8. PROFILE Page	58
3.5.9. STEPS Page	59
4. MODBUS REGISTERS	60
4.1. Profile Programs Modbus Registers	65
4.2. Profile Steps Modbus Registers	66

1. DEFINITION

E-220 Series universal process control devices are designed for on/off and PID control using an advanced new generation microcontroller. These 96x96 mm industrial devices have a TFT display, conform to the IEC/TR 60668 standard and the universal inputs and outputs are easily programmable by the user.

- High-Precision Reading
- Ease of Use
- Calibration Unaffected by Time and External Factors
- High Input Impedance
- Broken Sensor Detection

They are used in all fields of industry including measurement and control of temperature, pressure, level, speed, current, voltage, resistance and other physical units in iron and steel, cement, chemistry, food, plastics, petrochemistry, refinery, ceramics, glass and other industries.

2. TECHNICAL SPECIFICATIONS

Input Types	Thermocouple (TC) : B, E, J, K, L, N, R, S, T, U Resistance Thermometer (RT) : Pt-100 Current : 0-20 mA, 4-20 mA (Linear) Voltage : 0-50 mV, 0-1 V, 0.2-1 V (Linear)
Control Output	Relay : SPST-NO 250V AC, 5A Current : 0-20 mA, 4-20 mA (isolated) Pulse : 24V DC, 25 mA (for SSR)
Alarm Outputs	Relay : SPST-NO 250V AC, 5A
Display Type	320 x 240 TFT Color
Accuracy Class	Thermocouple : (±%0.5) or ±1 °C read value max. ±1 digit Pt-100 : (±%0.5) or ±1 °C read value max. ±1 digit Voltage/Current : ±%0.5 FS max. ±1 digit
Analog-Digital Converter	16 bit
Digital-Analog Converter	16 bit
Control Type	ON/OFF, PID
Operating Voltage	85-265 V AC / 85-375 V DC 20-60 V AC / 20-70 V DC
Power Consumption	7W (10 VA)
Protection Class	Front Panel : IP 66 (NEMA 4X) Back Panel : IP 20
Operation Temperature	-10 °C, +55 °C (+14 °F, +131 °F) (Without Condensation and Icing)
Storage Temperature	-25 °C, +65 °C (-13 °F, +149 °F) (Without Condensation and Icing)
Mechanical Life of Relays	10.000.000 on-off (Operating life of the relays varies according to configuration of use. Contacts of expired relays may melt or burn.)
Electrical Life of Relays	>1.000.000 on-off cycles (1/10 load)
Weight	430 g

2.1. Input Types

TEMPERATURE SENSORS

Sensor Type	Standard	Temperature Range	
		(°C)	(°F)
TYPE-B	IEC584-1	60 , 1820	140 , 3308
TYPE-E	IEC584-1	-200 , 840	-328 , 1544
TYPE-J	IEC584-1	-200 , 1120	-328 , 1562
TYPE-K	IEC584-1	-200 , 1360	-328 , 2480
TYPE-L	DIN43710	-200 , 900	-328 , 1652
TYPE-N	IEC584-1	-200 , 1300	-328 , 2372
TYPE-R	IEC584-1	-40 , 1760	104 , 3200
TYPE-S	IEC584-1	-40 , 1760	104 , 3200
TYPE-T	IEC584-1	-200 , 400	-328 , 752
TYPE-U	DIN43710	-200 , 600	-328 , 1112
PT-100	IEC751	-200 , 840	-328 , 1544

LINEAR INPUTS

Type	Measurement Range
Current 0-20 mA	0-20 mA DC
Current 4-20 mA	4-20 mA DC
Voltage 0-50 mV	0-50 mV DC
Voltage 0-1 V	0-1 V DC
Voltage 0.2-1 V	0.2-1 V DC

2.2. Type Coding

E-220-W-X-Y-Z

W Relay Outputs

- 2- 2 relays (RL1, RL2)
- 3- 3 relays (RL1, RL2, RL3)
- 4- 4 relays (RL1, RL2, RL3, RL4)
- 5- 1 SSR (SSR1) + 1 relay (RL2)
- 6- 1 SSR (SSR1) + 2 relays (RL2, RL3)
- 7- 1 SSR (SSR1) + 3 relays (RL2, RL3, RL4)
- 8- 2 SSR (SSR1, SSR2) + 1 relay (RL3)
- 9- 2 SSR (SSR1, SSR2) + 2 relays (RL3, RL4)

X Analog Output

- 1- 1 analog output 0-20/4-20 mA (AO1)
- 2- 2 analog outputs 0-20/4-20 mA (AO1, AO2)
- 3- 1 analog output 0-10V DC (AO1)
- 4- 2 analog outputs 0-10V DC (AO1, AO2)
- 5- 1 analog output 0-20/4-20 mA (AO1)
1 analog output 0-10V DC (AO2)

Analog outputs (AO1, AO2) are isolated from each other.

Y Communication and Digital Inputs

- 0- None
- 1- RS-485 Modbus
- 2- 3 Digital Inputs
- 3- 3 Digital Inputs + RS485 Modbus

Z Operating Voltage

- 0- 85 - 265 V AC; 85 - 375 V DC
- 1- 20 - 60 V AC; 20 - 70 V DC

2.3. Dimensions

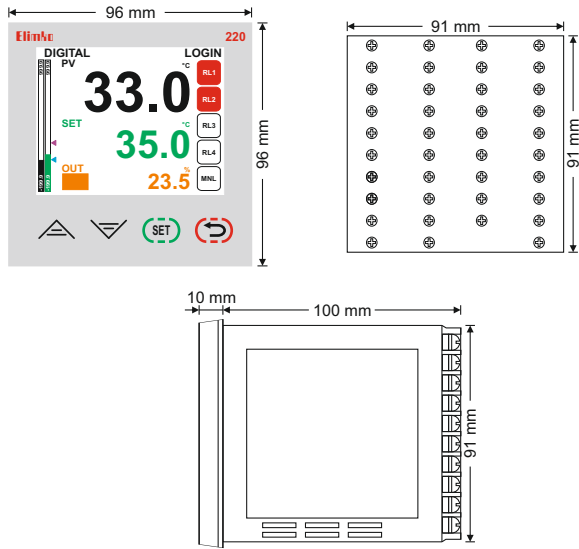

2.4. Panel Mounting

- E-220 must be installed and operated in grounded metal panels. This use will prevent human hand and metal tools from reaching high voltage.
- Appropriate fuses or switches must be used in the supply line and power outputs of the devices.
- To reduce the effects of electrical noise, pay attention to wiring of low-voltage lines (especially the sensor input cables) separately from the high-current and voltage lines. If this is not possible, use a shielded cable.
- Power supply cables must meet the requirements of IEC 60245 or IEC 60227 standards.

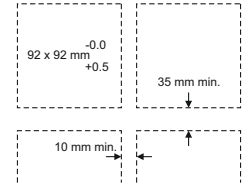
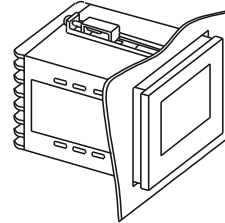

Panel Cut - Out

- Open the slot on the panel as shown in the figure above.
- Place the device in the slot from the front of the panel.
- Place the clamps by fitting the clamp tabs into their slots on the device.
- Tighten the screws until the clamps are secured to the panel surface.

2.5. Connection Diagram

- Optional features are marked on the connection diagram. Connections must comply with optional features.
- Optional features are marked in the connection diagram. Connections must comply with optional specifications.

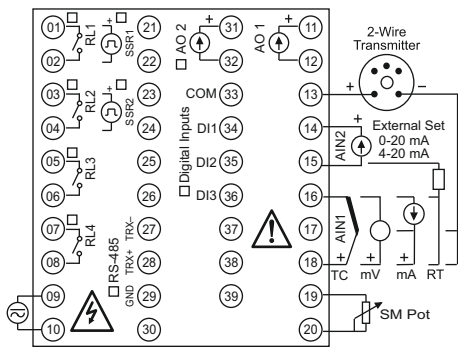

□ 20-60VAC; 50-60 Hz / 20-85VDC □ 85-265VAC; 50-60 Hz / 85-375VDC

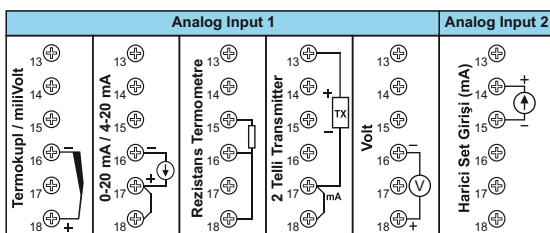

- Do not touch the terminals 01-10 while the device is energized as dangerous voltage levels are present.
- Make sure that the parameters were set for the intended use before commissioning the device. Incorrect configuration may cause damage.



(*) Digital Input Connection

- DI1** Auto/Manual mode selection.
- DI2 ve DI3** When SET TYPE is DIGITAL; DIGITAL SET1, DIGITAL SET2, DIGITAL SET3, DIGITAL SET4 parameters in SET settings page are selected for SV value according to the following table.

DI2	DI3	0 / 1 = ON / OFF
0	0	DIGITAL SET1
0	1	DIGITAL SET2
1	0	DIGITAL SET3
1	1	DIGITAL SET4

*AO1, AO2 Analog Outputs, Pulse Output ve Digital Inputs are not isolated from each others.

2.6. E-220 Front Panel

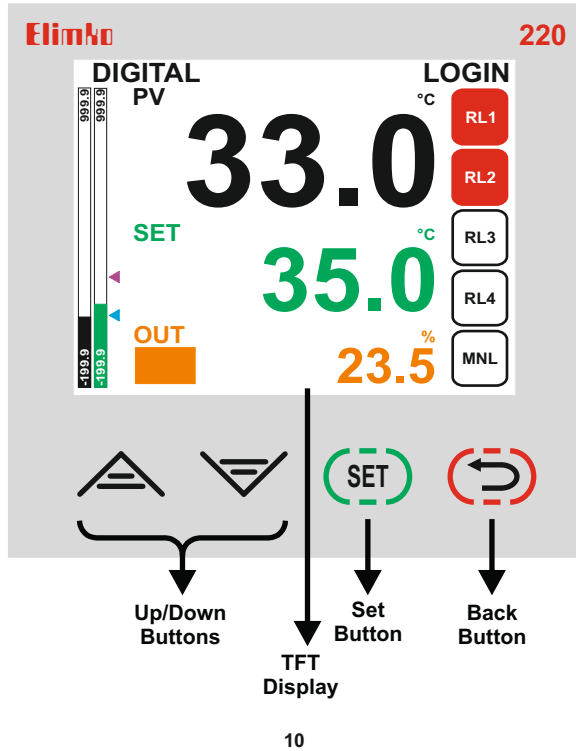

10

3. USAGE

3.1. Device Energization and Start Page

Start screen showing the device type and software version is given in Figure 3.1 This screen is displayed for at least 5 seconds after the device is energized and after this time the device switches to the DIGITAL operator page.

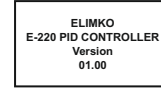

Figure 3.1

3.2. Title Area

TITLE AREA is always displayed at the top of the screens in two different versions (see Figure 3.2 and 3.3). On pages where process value is not available, Figure 3.3 style title appears, otherwise TITLE AREA is shown as in Figure 3.2.

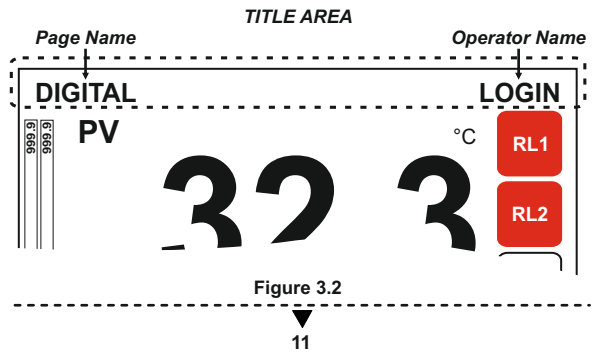

Figure 3.2

11

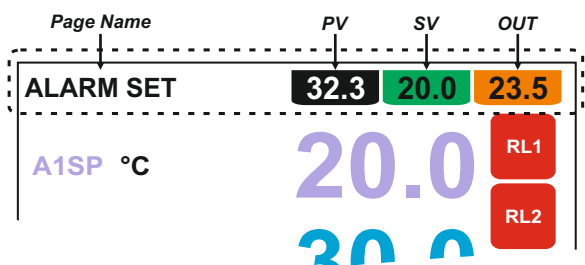

Figure 3.3

If a valid password is not entered, Operator Name field appears as LOGIN. If a valid operator password is entered, name of the operator that logged in appears.

For E-220 devices, switching between operator pages is done with [Back] Button.

In the event of an alarm, alarm message flashes on the TITLE AREA. The predefined alarm messages are listed below.

- 1 - SENSOR OPEN
- 2 - SENSOR UFL
- 3 - SENSOR OFL

3.3. LED Indicators and Meaning

On the right-hand side of the operator pages, LED indicators are continuously displayed. Please see below for the indicator explanations.

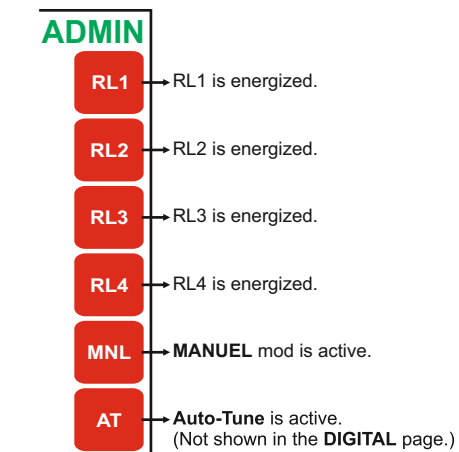

3.4. Operator Pages

The device has 4 operator pages for different views and operations. The device opens in first enabled operator page. Operator pages are listed below.



Switch between enabled operator pages by pressing (↺). Please see below.

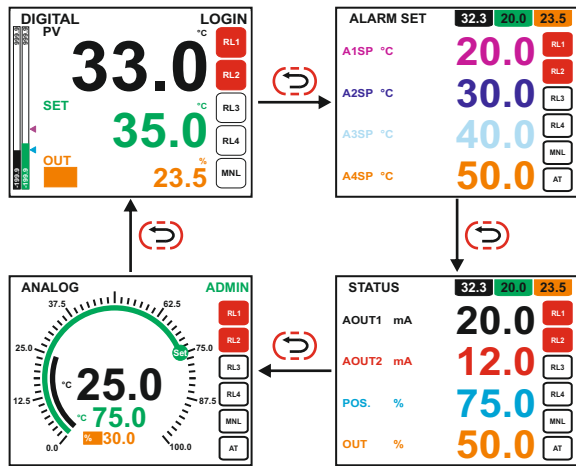

Press (SET) and (↺) buttons together to access MENU screen. Press (↺) to exit this screen.

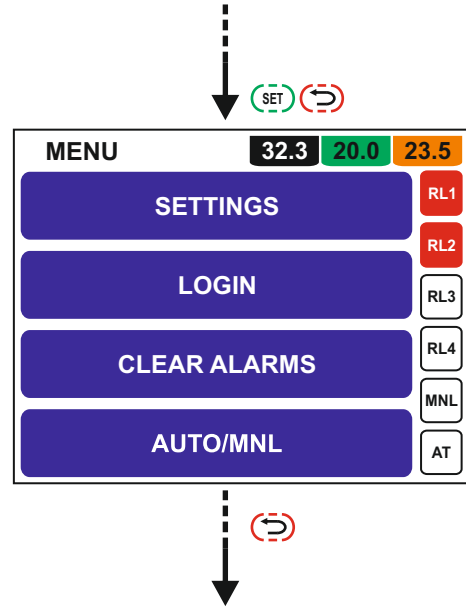

3.4.1. ANALOG Operator Page

On this operator page, PV and SV are graphically displayed on a circular scale. The lower scale of the circular graph is equal to the SET POINT LOWER value and the upper scale to the SET POINT UPPER value. Set value is shown on green scale and PV is displayed on white scale.

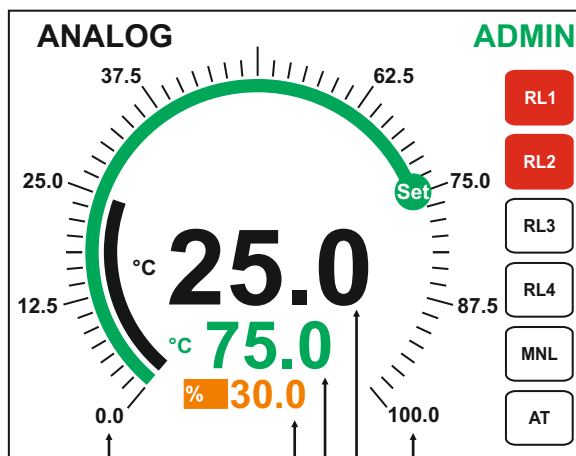

In addition to the circular display, PV, SV and OUT values can be monitored digitally on this screen. PV is shown as white, SV as green and OUT as yellow bar graphs.

In this page, SV or OUT can be set according to device operation mode. The logged in user must have authorization to change the parameter to be set. SV can be set in AUTO mode and OUT can be set in MANUAL mode. OUT is not displayed when CONTROL TYPE is BOUNDLESS.

In E-220 series devices, it can be set to desired value by using ▲ and ▼ buttons after pressing SV (SET) button in AUTO mode and saved by pressing (SET) button again. In MANUAL mode, OUT can be set using the same buttons.

3.4.2. DIGITAL Operator Page

PV and SV bar graphs can be viewed on this operator page. The bar graph of PV is plotted on the left side of the screen using the ZERO and SPAN scale. Similarly, the SV bar graph is shown in green color on the right side of the PV bar graph. In addition to these graphs, the levels of active alarm setpoints are shown on the right side of the SV bar graph with triangular markings in their respective colors.

ALARM 1	ALARM 2	ALARM 3	ALARM 4
MAGENTA	BLUE	CYAN	YELLOW

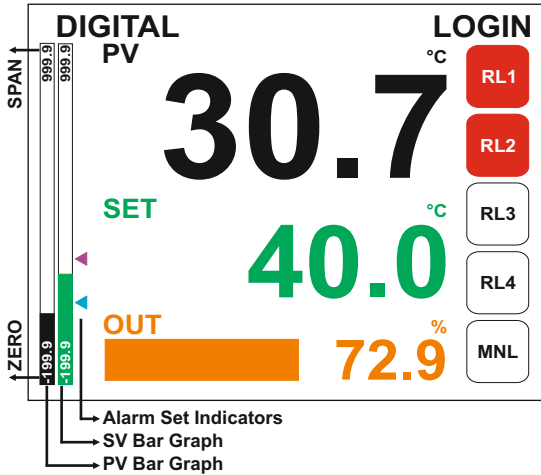

In addition to the bar graph view, PV, SV and OUT values can be monitored digitally on this screen. PV is shown as white, SV as green and OUT as yellow bar graphs.

In this page, SV or OUT can be set according to device operation mode. The logged in user must have authorization to change the parameter to be set. SV can be set in AUTO mode and OUT can be set in MANUAL mode. OUT is not displayed when the CONTROL TYPE is BOUNDLESS and instead the valve ON and OFF signals of the BOUNDLESS CONTROL are shown.

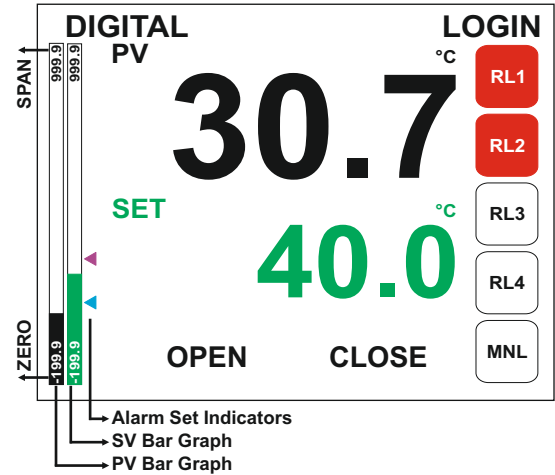

SV can be set to desired value by using ▲ and ▼ buttons after pressing (SET) button in AUTO mode and saved by pressing (SAVE) button again. In MANUAL mode, OUT can be set using the same buttons. If the CONTROL TYPE is BOUNDLESS in MANUAL mode, valve ON and OFF signals are displayed as buttons instead of digital value OUT. To manually control these signals, first press the SET button, then select the desired signal to be changed using the ▲ and ▼ buttons, and press and hold the (SET) button again to activate the selected signal for the duration of the hold.

The DIGITAL operator page view changes accordingly when SET POINT SOURCE is PROFILE is selected, and additional parameter appears on the screen related to profile control.

The profile number to be executed can be selected from the PRFL field and the number of repeats can be selected from the Repeat field. When the RUN button is pressed, the selected profile can be operated for the selected number of repetitions. The HOLD button stops the running profile. The STOP button ends the profile. While the profile is running, the Step No, Remaining Time and Remaining Repetitions are shown in the bottom line. The profile number and number of repetitions cannot be changed while the profile is running. To change the profile, you can enter the new profile after terminating the active profile by pressing STOP.

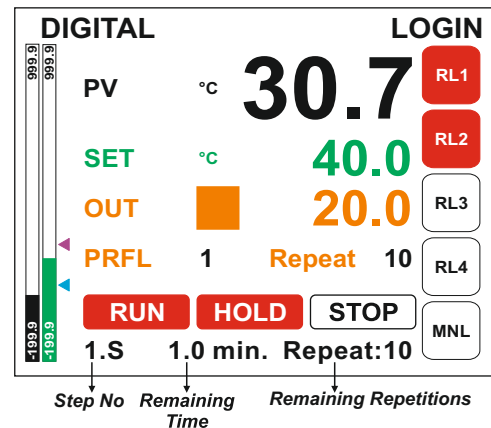

Note: Monitored when the profile is active.

3.4.3. ALARM SET Operator Page

On this operator page;

**A1SP (ALARM 1 SET),
A2SP (ALARM 2 SET),
A3SP (ALARM 3 SET),
A4SP (ALARM 4 SET)** alarm set values can be monitored and changed. To make changes, the logged in user must have authorization to change the parameter to be set.

First desired set point is selected by using ▲ and ▼ buttons. (SET) button is pressed to enter change mode and adjustment is done using ▲ and ▼ buttons. The changed value is saved by pressing (SET) button again.

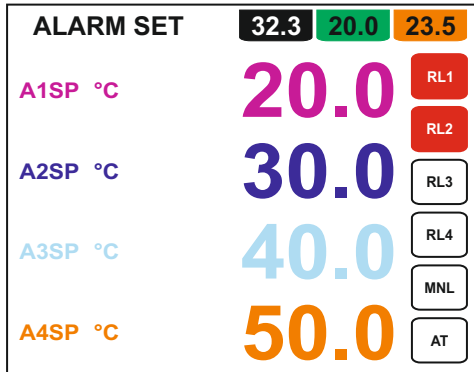

3.4.4. STATUS Operator Page

On this operator page **AOUT1, AOUT2, Position** and **OUT** values can be monitored.

AOUT1 : Analog Output 1 current value
AOUT2 : Analog Output 2 current value
POS. : Feedback servo motor position

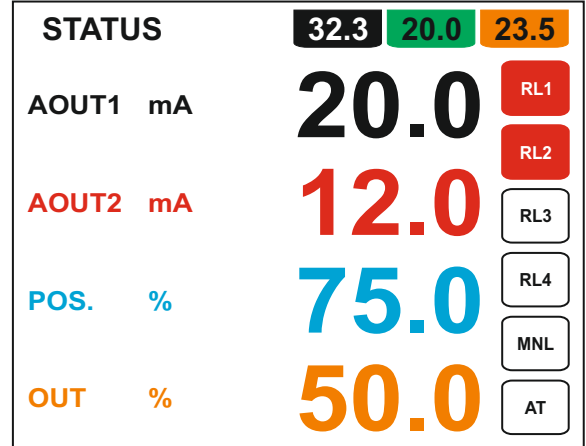

3.5. SETTINGS

(SET) and (↺) buttons are pressed together to reach **MENU**. The device powers on in unauthorized state (with no user logged in). In order to turn it into authorized state, a user must login first. When no user logged in state, pressing (SET) and (↺) buttons asks for user login otherwise directly shows MENU.

This page contains buttons for each of the 4 operator functions. Descriptions of operator functions are given below. Some functions may not be active depending on the logged in operator's privileges and device settings.

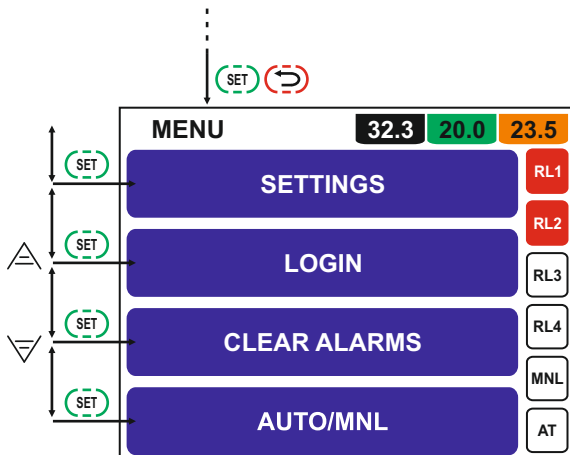

◆ SETTINGS

Provides access to pages where all the device parameters are set. This operation is active for all users, but the parameters that can be set are limited depending on user privileges.

◆ LOGIN

Used for operator login. After selecting this function, the password of the operator to be logged in must be entered. If the operator is already logged in, this button appears as the name of the previously logged operator and pressing this button logs out the operator.

◆ CLEAR ALARMS

If an alarm occurs with the **ALARM LATCH** parameter set to **ON**, alarms can be resolved using this function.

◆ AUTO/MNL

This function is used to change the operation mode of the device. The current operating mode can be monitored from the **MANUAL LED** display. For this function to be active, the **MANUAL SWITCH** parameter must be set to **ON**.

3.5.1. Settings Parameters

SETTINGS page provides access to sub pages where all the device parameters are set. Device parameters are divided into 8 main groups. Depending on the privileges of the logged-in user, the ability to change parameters is limited.

Desired parameter group must be selected by using the ▲ and ▼ buttons first and after the selection, the selected group is accessed by pressing the (SET) button.

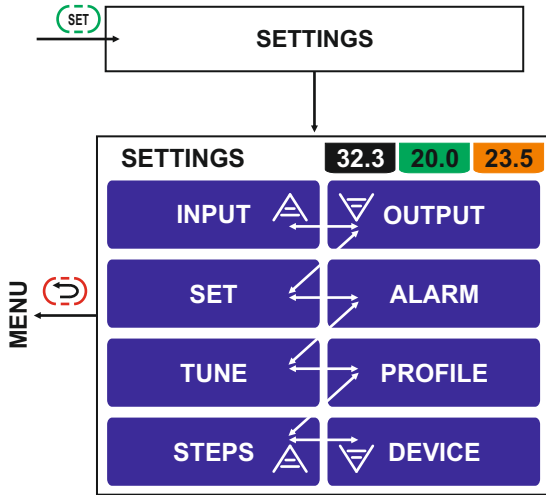

Most of the parameters set on the device (Table 3.1) depend on the **DECIMAL POINT** parameter which resides in **INPUT** page. The **DECIMAL POINT** parameter must be set before setting any other parameter.

As an example, the screen shot for the **OUTPUT** settings page is shown in Figure 3.4. Name of the adjusted page is monitored on the header section of the page. Return to the main menu by pressing (MENU).

In the header section, **PV, SV** and **OUT** values are also continuously monitored. In the rest of the page, parameter names and values are monitored.

First, desired parameter to be set is selected by using ▲ and ▼ buttons. (SET) button is pressed to enter change mode and adjustment is done using ▲ and ▼ buttons. The changed value is saved by pressing (SET) button again. Upon saving, next valid parameter is selected.

Table 3.1: Parameters depending on **DECIMAL POINT** parameter

◆ CONTROL SET POINT	◆ SET POINT RAMP
◆ PROPORTIONAL+	◆ DIGITAL SET POINTS
◆ PROPORTIONAL-	◆ ALARM SET POINT
◆ INTEGRAL+	◆ ALARM HYSTERESIS VALUE
◆ INTEGRAL-	◆ ZERO
◆ DERIVATIVE+	◆ SPAN
◆ DERIVATIVE-	◆ RETRANSMISSION LOW
◆ HYSTERESIS	◆ RETRANSMISSION HIGH
◆ SET POINT LOW	◆ OFFSET
◆ SET POINT HIGH	◆ PROFILE SET VALUES

While on any configuration page, the parameter to be adjusted is selected by using the (SET) button. Selected parameter ▲ and ▼ changed with buttons. 7 parameters can be monitored on each page.

If the (SET) button is pressed after coming to the last parameter on the page, it will automatically move to the next page. Page number title displayed in the field. Press (SET) while in any parameter. If pressed long, the first parameter on the first page, if pressed short, a the next parameter is passed.

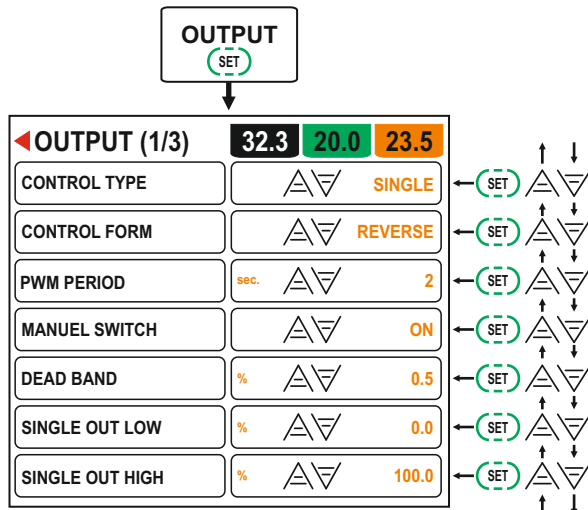

Figure 3.4

3.5.2. INPUT Page

◆ **ANALOG INPUT1 (AIN1)**

1. Analog Input Type (AIN1).

Specifies the input type to be connected for PV (Process Value) measurement.

	Sensor Type	Standard	Range		
			(°C)	(°F)	
Temperature Sensors	0	TYPE-B	IEC584-1	60 , 1820	140 , 3308
	1	TYPE-E	IEC584-1	-200 , 840	-328 , 1544
	2	TYPE-J	IEC584-1	-200 , 1120	-328 , 1562
	3	TYPE-K	IEC584-1	-200 , 1360	-328 , 2480
	4	TYPE-L	DIN43710	-200 , 900	-328 , 1652
	5	TYPE-N	IEC584-1	-200 , 1300	-328 , 2372
	6	TYPE-R	IEC584-1	-40 , 1760	104 , 3200
	7	TYPE-S	IEC584-1	-40 , 1760	104 , 3200
	8	TYPE-T	IEC584-1	-200 , 400	-328 , 752
	9	TYPE-U	DIN43710	-200 , 600	-328 , 1112
10	PT-100	IEC751	-200 , 840	-328 , 1544	
Linear Inputs	11	0-20 mA	Current	0-20 mA DC	
	12	4-20 mA	Current	4-20 mA DC	
	13	0-50 mV	Voltage	0-50 mV DC	
	14	0-1 V	Voltage	0-1 V DC	
	15	0.2-1 V	Voltage	0.2-1 V DC	

◆ **EXTERNAL SET (AIN2)**

External Set Input Type (AIN2).

Determines the range of the external mA input signal to measure the SV value when **SET POINT SOURCE** is set to **EXTERNAL**. It can be selected as 0-20 mA or 4-20 mA. **SET POINT LOW** and **SET POINT HIGH** parameters are used as calculation scale.

◆ **DECIMAL POINT**

The location of the decimal point.

It can be set between 0-1 for temperature sensors (TC, RT) and 0-3 for linear inputs (mA, mV, V). When this parameter is changed, all parameters given in **Table 3.1** must be corrected according to the point location. This parameter should be set prior to any other adjustment.

◆ **ZERO**

Lower value of the scale for linear input types.

This parameter is monitored when **ANALOG INPUT 1** is set to one of the linear inputs. It can be set between -1999 and 9999.

◆ **SPAN**

Upper value of the scale for linear input types.

This parameter is monitored when **ANALOG INPUT 1** is set to one of the linear inputs. It can be set between -1999 and 9999.

◆ **TEMPERATURE UNIT**

Temperature sensor unit.

This parameter is monitored when **ANALOG INPUT 1** is set to one of the temperature inputs. It can be selected as °C or °F.

◆ **LINEAR UNIT**

Linear input unit.

This parameter is monitored when **ANALOG INPUT 1** is set to one of the linear inputs.

0-mA,	7-mbar,	14-cm,
1-A,	8-kpa,	15-mm,
2-kA,	9-Hz,	16-MW,
3-mV,	10-m3/h,	17-Kw,
4-V,	11-t/s,	18-W,
5-kV,	12-%RH,	19-mW,
6-bar,	13-m,	20-kohm

can be selected.

◆ **OFFSET:**

ANALOG INPUT 1 Measurement Offset Value.

The value specified in this parameter is added to the PV value. It can be set between -1000 and 1000.

◆ **FILTER**

ANALOG INPUT 1 PV value filtering time.

The sampling time of the PV value is 500 ms. Two samples are taken for each second. PV value can be averaged in order to suppress high frequency noise. **FILTER** parameter determines averaging time. For example, if this parameter is set to 4 seconds, the last 8 measurements are averaged.

It can be set between 1 and 16 (seconds).

◆ **SENSOR BREAK**

1. Analog Input Sensor Broken Behaviour.

In all temperature sensors and when the linear input 4-20 mA is selected, the breaks in the input connections are detected by the device.

This parameter determines the PV, when the device detects breaks in the input connections.

LOW Process value is set to -20000.

HIGH Process value is set to 20000.

If the input is broken, PV value is displayed as ■■■■ on the screen. The message **SENSOR OPEN** is displayed in the title section.

In addition to the **SENSOR OPEN** condition, **UFL** (Under Flow) and **OFL** (Over Flow) conditions for standard temperature sensors are also detected by the device. These states are monitored when a signal outside the standard sensor range is measured. Error messages are displayed as **SENSOR UFL** and **SENSOR OFL** in the title section.

◆ **MODBUS ADDRESS, BAUD RATE, PARITY**

Modbus RTU slave protocol communication parameters.

See section 4. **MODBUS REGISTERS** for communication addresses.

◆ **MODBUS ADDRESS**

It can be set between 1 and 127.

◆ **BAUD RATE**

Baud Rate.

0-4800,
1-9600,
2-19200 or
3-38400 (baud) can be set.

◆ **PARITY**

Parity Type.

It can be set to **NONE, ODD** or **EVEN**.

The following figure shows the feedback valve connection using RL1 and RL2.

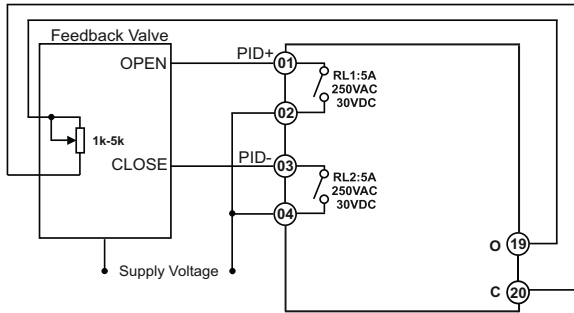

SINGLE OUT LOW and **SINGLE OUT HIGH** parameters determine the minimum and maximum positions of the feedback valve during the control.

SINGLE MNL. RESET parameter is only active when the **INTEGRAL+** parameter is set to "0" and this value is automatically added to the valve position.

If the difference between the calculated valve position and the current valve position is less than the value set by **DEAD BAND**, the valve position is not changed.

4-BOUNDLESS (Floating valve control)

This control type must be selected when the control element is a floating valve (no feedback).

The **PID+** and **PID-** signals that control the **OPEN** and **CLOSE** inputs of the non-feedback valve are calculated using the **VALVE TRAVEL TIME** parameter. **VALVE TRAVEL TIME** parameter specifies the time required for the valve to move from the most closed to the most open position.

Valve control is activated by directing **PID+** and **PID-** to the desired relays by adjusting **RL SOURCE** parameters.

The following figure shows the floating valve connection using **RL1** and **RL2**.

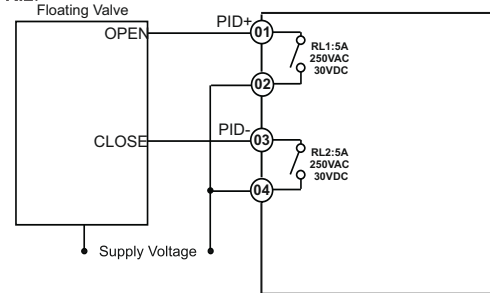

If the difference between the calculated valve position and the current valve position is less than the value set by **DEAD BAND**, the valve position is not changed.

◆ **CONTROL FORM**

It can be set to **REVERSE** or **DIRECT**.

When **REVERSE** is selected, the control signal reacts inversely to the error signal. This means that the control signal decreases when the process value is higher than the set value, and vice versa.

When **DIRECT** is selected, the control signal reacts in the same way as the error signal. This means that the control signal increases when the process value is higher than the set value.

◆ **PWM PERIOD**

It determines the PWM period when the **PID+** and **PID-** control signals are output as PWM from relay or SSR outputs. It can be set between **1** and **250 (seconds)**.

◆ **MANUAL SWITCH**

It can be set to **ON** or **OFF**. If set to **ON**, the device can also be controlled manually. Refer to the operator's pages for manual operation of the device. This parameter is not monitored if **CONTROL TYPE** is **OFF**.

◆ **VALVE TRAVEL TIME**

Floating Valve Travel Time
Time can be set between **10** and **2500 (sec.)**. This is monitored only if **CONTROL TYPE** is **BOUNDLESS**. For a detailed description of this parameter, see the **CONTROL TYPE** parameter.

◆ **DEAD BAND**

Control Output Dead Band

It can be set between **0.1** and **25.0 (%)**.

This parameter is not monitored if **CONTROL TYPE OFF** is selected. For a detailed description of this parameter, see the **CONTROL TYPE** parameter.

◆ **SINGLE OUT LOW**

Single (+) Control Output Low Limit

It can be set between **0.0** and **SINGLE MNL. RESET (%)**.

This parameter is not monitored if **CONTROL TYPE** is **OFF** or **DOUBLE**.

For a detailed description of this parameter, see the **CONTROL TYPE** parameter.

◆ **SINGLE OUT HIGH**

Single (+) Control Output High Limit

It can be set between **SINGLE MNL. RESET** and **100.0 (%)**.

This parameter is not monitored if **CONTROL TYPE** is **OFF** or **DOUBLE**.

For a detailed description of this parameter, see the **CONTROL TYPE** parameter.

3.5.3. OUTPUT Page

◆ **CONTROL TYPE**

- 0-OFF** (No control),
- 1-SINGLE** (One-way (+) control),
- 2-DOUBLE** (Two-way (+/-) control),
- 3-SERVO** (Feedback valve control)
- 4-BOUNDLESS** (Non-feedback valve control)

can be selected.

Depending on the control type selected, the device calculates the analog and digital control signals listed below.

PID + positive (+) directional PID control signal. This signal changes the process value in positive direction.

PID - negative (-) directional PID control signal. This signal changes the process value in negative direction.

ONOFF+ positive (+) directional ONOFF control signal. This signal changes the process value in positive direction.

ONOFF- negative (-) directional ONOFF control signal. This signal changes the process value in negative direction.

 Detailed descriptions for the control types are given below.

1- SINGLE (One-way (+) Control)

In this control type, only the positive **PID+** and **ONOFF+** signals are calculated.

The upper and lower value of the **PID+** signal can be set in % with **SINGLE OUT LOW** and **SINGLE OUT HIGH** parameters.

SINGLE MNL. RESET parameter is only active when the **INTEGRAL+** parameter is set to "0" and this value is automatically added to the **PID+** signal.

PID+ and **ONOFF+** signals can be transmitted to the desired outputs using the **RL SOURCE** and **AO SOURCE** parameters.

When **PID+** signal is transferred to the relays, it is given as **PWM**. The value of PWM period is set by parameter **PWM PERIOD**.

The output is not given when the **PID+** signal is smaller than the percentage of output specified in the **DEAD BAND** parameter.

2- DOUBLE (Two-way (+/-) Control)

In this control type, **PID+**, **PID-**, **ONOFF+** and **ONOFF-** signals in positive and negative directions are calculated. This type of control should be used in Heat-Cool applications.

The upper value of the **PID+** signal is determined by the parameter **DOUBLE OUT HIGH**. The lower value is "0". If the **PID+** signal is smaller than the **DEAD BAND** parameter, it is set to "0".

The lower value of the **PID-** signal is determined by the parameter **DOUBLE OUT LOW**. The upper value is "0". If the **PID-** signal is smaller than the negative of **DEAD BAND** parameter, it is set to "0".

DOUBLE MNL. RESET parameter is only active when the **INTEGRAL+** and **INTEGRAL-** parameters are set to "0" and this value is automatically added to the **PID+** and **PID-** signals.

PID+, **PID-**, **ONOFF-** and **ONOFF+** signals can be transmitted to the desired outputs using the **RL SOURCE** and **AO SOURCE** parameters.

When **PID+** and **PID-** signals are transferred to the relays, they are given as **PWM**. The value of PWM period is set by parameter **PWM PERIOD**.

3-SERVO (Feedback valve control)

This control type must be selected when the control element is a feedback valve.

The parameters **SERVO LOW POSITION** and **SERVO HIGH POSITION** must be set before starting this control.

In order to save the parameters of **SERVO LOW POSITION** and **SERVO HIGH POSITION** on E-220 devices, the related parameter is selected first. When these parameters are selected, the ▾ button turns the servo off and the ▲ button turns the servo on. After the servo is set to the desired position, the value is saved by pressing ▲ and ▾ buttons together.

The **PID+** and **PID-** signals that control the **OPEN** and **CLOSE** inputs of the feedback valve are calculated using the feedback input. The feedback signal must be connected to terminals 19 and 20. The feedback resistance should be between 1kohm and 5kohm.

Feedback valve control is activated by directing **PID+** and **PID-** to the desired relays by adjusting **RL SOURCE** parameters.

◆ **SINGLE MNL. RESET**

Single (+) Control Output Manual Reset Value

It can be set between **SINGLE OUT LOW** and **SINGLE OUT HIGH (%)**.

This parameter is not monitored if **CONTROL TYPE** is **OFF** or **DOUBLE**.

For a detailed description of this parameter, see the **CONTROL TYPE** parameter.

◆ **DOUBLE OUT LOW**

Double (+/-) Control Output Low Limit

It can be set between **-100.0** and **DOUBLE MNL. RESET (%)**.

This parameter is monitored only if **CONTROL TYPE** is **DOUBLE**.

For a detailed description of this parameter, see the **CONTROL TYPE** parameter.

◆ **DOUBLE OUT HIGH**

Double (+/-) Control Output High Limit

It can be set between **DOUBLE MNL. RESET** and **100.0 (%)**.

This parameter is monitored only if **CONTROL TYPE** is **DOUBLE**.

For a detailed description of this parameter, see the **CONTROL TYPE** parameter.

◆ **DOUBLE MNL. RESET**

Double (+) Control Output Manual Reset Limit

It can be set between **DOUBLE OUT LOW** and **DOUBLE OUT HIGH (%)**.

This parameter is monitored only if **CONTROL TYPE** is **DOUBLE**.

For a detailed description of this parameter, see the **CONTROL TYPE** parameter.

◆ **POWER ON ACTION**

PID Control Energizing Behaviour.

The first time the device is energized, it determines whether any change in the control parameters should be made.

0-NONE

No changes are made. It starts operating with the last control values.

1-AUTO

The device switches to **AUTO** mode if it was in **MANUAL** mode at the moment of power-down when the device is first energized.

2-AUTO (INT=0)

The device switches to **AUTO** mode if it was in **MANUAL** mode at the moment of power-down when the device is first energized. Integral value is reset.

3-MANUAL

The device switches to **MANUAL** mode if it was in **AUTO** mode at the moment of power-down when the device is first energized.

4-MANUAL (OUT=0)

The device switches to **MANUAL** mode if it was in **AUTO** mode at the moment of power-down when the device is first energized. OUT value is reset.

This parameter is not monitored if **CONTROL TYPE** is **OFF**.

◆ **RL1 SOURCE, RL2 SOURCE, RL3 SOURCE, RL4 SOURCE**

Relay Function Selections

These are the parameters that determine which outputs will be taken from 4 relays in the device.

0-PID+ (PID control output in "+" direction)

1-PID- (PID control output in "-" direction)

2-ONOFF+ (On/Off control output in "+" direction)

3-ONOFF- (On/Off control output in "-" direction)

4-ALARM-1 (Alarm-1 warning)

5-ALARM-2 (Alarm-2 warning)

6-ALARM-3 (Alarm-3 warning)

7-ALARM-4 (Alarm-4 warning)

8-ALARM-A (ALARM-A warning during step)

9-ALARM-B (ALARM-B warning during step)

10-ALARM-C (ALARM-C warning during step)

11-ALARM-D (ALARM-D warning during step)

12-ALARM-O (Hold at deviation and give ALARM-O warning)

13-ALARM-H (Hold at step start and give ALARM-H warning)

14-ALARM-E (Profile complete warning) can be selected.

◆ SET POINT HIGH

Set Point High Limit.
 It can be set between **SET POINT LOW** and **9999**.
 Specifies the highest value at which the setpoint can be set when the **SET POINT SOURCE** is **INTERNAL**.
 Sets the upper scale of input **AIN2** when **SET POINT SOURCE** is **EXTERNAL**.
 Sets the upper value of digitally selected set values when **SET POINT SOURCE** is **DIGITAL**.

◆ SET POINT RAMP

Set Point Ramp Rate
 If this parameter is set to a value other than zero, the SV value moves to the changed value at the rate specified with this parameter during set point changes. For example, when this parameter 10 is selected, SV value changes 10 per minute.
 It can be set between **0.0** and **60 (/min)**.

◆ DIGITAL SET1, DIGITAL SET2, DIGITAL SET3, DIGITAL SET4

Digitally Selected Set Points
 It can be set between **SET POINT LOW** and **SET POINT HIGH**.
 These are monitored only if **SET POINT SOURCE** is **DIGITAL**.

◆ PROFIL POWERON

If the power supply goes off while the profile is running, this parameter determines how the profile program will continue upon the power supply is applied.
0-NO CHANGE : Continues without any change.
1-HOLD : Profile is holded.
2-STEP START : Continues from start of last running step.
3-STEP START H. : Reverts to start of last running step and is holded.
4-STOP : Profile is stopped.
 This parameter is monitored only if **SET POINT SOURCE** is **PROFILE**.

3.5.5. ALARM Page

ALARM TYPE, ALARM SET, ALARM HYSTERESIS, ALARM LATCH

4 different alarms can be defined in the device. There are **ALARM TYPE, ALARM SET, ALARM HYSTERESIS, ALARM LATCH** parameters for each alarm. The options and descriptions of these parameters are given below.

The device calculates the status information of 4 alarms and transmits them to **ALARM-1, ALARM-2, ALARM-3, ALARM-4** signals. To transmit these signals to relay outputs, **RL1 SOURCE, RL2 SOURCE, RL3 SOURCE, RL4 SOURCE** in **OUTPUT** page should be used.

Operation forms are different according to the parameters set for each alarm. See **Figure 3.5** for operating forms.

◆ ALARM TYPE

Sets the alarm type.

- 0-OFF
- 1-LOW
- 2-HIGH
- 3-LOW (SV+ASP)
- 4-HIGH (SV+ASP)
- 5-LOW BAND
- 6-HIGH BAND

◆ ALARM SET

Determines the alarm set value.
 It can be set between **-1999** ile **9999**.
 This parameter is not monitored if **ALARM TYPE** is **OFF**.

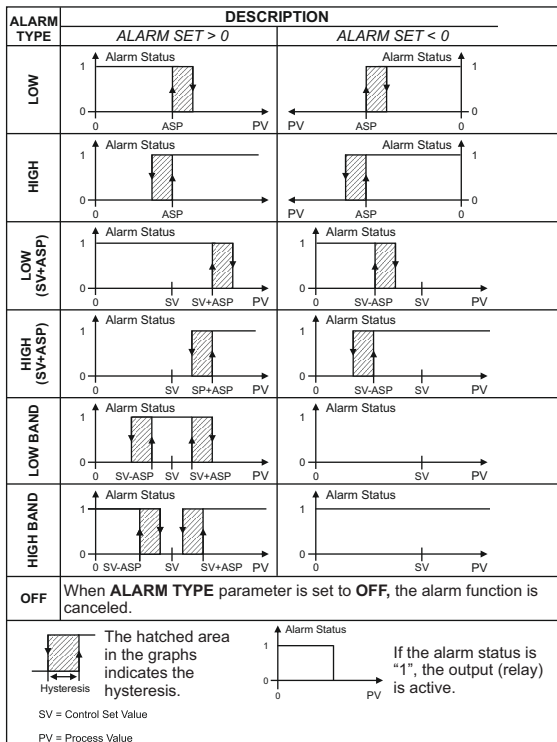

Figure 3.5

◆ ALARM HYSTERESIS

Determines the alarm hysteresis value.

It can be set between **0** and **9999**.

This parameter is not monitored if **ALARM TYPE** is **OFF**.

◆ ALARM LATCH

If **ALARM LATCH** is set to ON, the alarm signal is not cleared even if the alarm condition is released after the alarm has been detected.

To clear the alarm signal, press the (↵) button.

- 0-OFF
 - 1-ON
- can be selected.

This parameter is not monitored if **ALARM TYPE** is **OFF**.

◆ **AO1 SOURCE, AO2 SOURCE**

Analog Output Function Selections

These are the parameters that determine which signals will be taken from 2 analog outputs in the device.

0-PID+ (PID control output in "+" direction)

1-PID- (PID control output in "-" direction)

2-PV (Process value retransmission)

3-SET (Set point retransmission)

can be selected.

The output range of analog outputs is determined by parameters **AO1 RANGE** and **AO2 RANGE**.

The retransmission scale for **PID+** selection is **0%** and **100%**.

The retransmission scale for **PID-** is **0%** and **-100%**.

The process value and setpoint retransmission scale is determined by the **RETRANSMISSION LOW** and **RETRANSMISSION HIGH** parameters.

◆ **AO1 RANGE, AO2 RANGE**

Analog Output Signal Range

0- 0-20 mA, 4- 0-10 V,
1- 20-0 mA, 5- 10-0 V,
2- 4-20 mA, 6- 2-10 V,
3- 20-4 mA, 7- 10-2 V can be selected.

For a detailed description of this parameter, see the **AO1 SOURCE, AO2 SOURCE** parameters.

◆ **RETRANSMISSION LOW**

Retransmission Low Limit.

It can be set between **-1999** and **RETRANSMISSION HIGH**.

For a detailed description of this parameter, see the **AO1 SOURCE, AO2 SOURCE** parameters.

◆ **RETRANSMISSION HIGH**

Retransmission High Limit.

It can be set between **RETRANSMISSION LOW** and **9999**.

For a detailed description of this parameter, see the **AO1 SOURCE, AO2 SOURCE** parameters.

◆ **SERVO LOW POSITION**

Feedback Valve Fully Closed Position Setting

It can be set between **-32000** and **32000**.

This is monitored only if **CONTROL TYPE SERVO** is selected.

For a detailed description of this parameter, see the **CONTROL TYPE** parameter.

◆ **SERVO HIGH POSITION**

Feedback Valve Fully Closed Position Setting

It can be set between **-32000** and **32000**.

This is monitored only if **CONTROL TYPE SERVO** is selected.

For a detailed description of this parameter, see the **CONTROL TYPE** parameter.

3.5.4. SET Page

◆ **SET POINT SOURCE**

Set Point Source.

The control SV value can be taken from different sources according to the selection made in this parameter.

- 0-INTERNAL**, Manually entered.
- 1-EXTERNAL**, External Input (AIN2)
- 2-DIGITAL**, Selection by Digital Inputs
- 3-PROFILE**, with profile programs

When set to **DIGITAL**, the SV value is selected according to the signal applied to digital inputs **DI2** and **DI3**.

DI2	DI3	0 / 1 = ON / OFF
0	0	DIGITAL SET1
0	1	DIGITAL SET2
1	0	DIGITAL SET3
1	1	DIGITAL SET4

◆ **SET POINT LOW**

Set Point Lower Limit

It can be set between **-1999** and **SET POINT HIGH**.

Specifies the lowest value at which the setpoint can be set when the setpoint type is **INTERNAL**.

Sets the lower scale of input **AIN2** when setpoint type is **EXTERNAL**. Sets the lower value of **DIGITAL** set values when setpoint type is **DIGITAL**.

3.5.6. TUNE Page

◆ **AUTO TUNE**

This parameter initiates or cancel the Auto-Tune process. If **ON** is selected, auto-tune starts and remains in this state until it is completed. When the Auto-Tune operation is completed, this parameter is automatically set to **OFF** again. When this parameter is **ON**, the operator can cancel the auto-tune operation by manually turning it **OFF**.

The control setpoint (**SV**) and **HYSTERESIS** parameters must be set before starting Auto-Tune. The SV value should be set to the most commonly used operating value of the system. The recommended value for **HYSTERESIS** parameter is 0.5. For slow changing systems, this value can be set smaller values. For fast changing and noisy system, larger values is more suitable. The **HYSTERESIS** value should be set larger than the input noise.

The **AT** led will appear red during the Auto-Tune. The Auto-Tune procedure is illustrated in the graph below. The completion time varies according to the speed of the process.

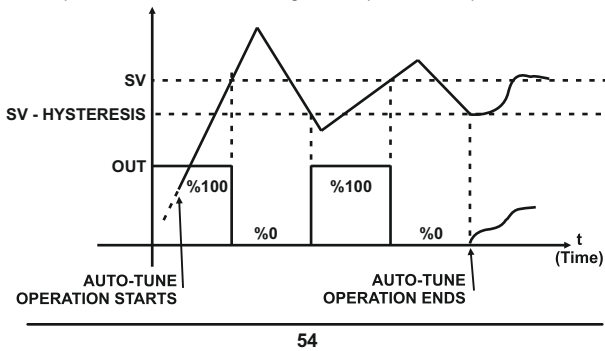

◆ **PROPORTIONAL+, PROPORTIONAL-**

Proportional Bands

Specifies the proportional band process unit for the PID control outputs in "+" and "-" directions.

It can be set between **1** and **9999**.

PROPORTIONAL+ is not monitored when **CONTROL TYPE** is **OFF**.

PROPORTIONAL- is monitored only when **CONTROL TYPE** is **DOUBLE**.

◆ **INTEGRAL+, INTEGRAL-**

Integral Times

Sets the integral times in seconds for error signals marked "+" and "-".

It can be set between **0** and **9999**. If "0" is selected, integral operation is not performed.

This is not monitored when **CONTROL TYPE** is **OFF**.

◆ **DERIVATIVE+, DERIVATIVE-**

Derivative Times

Sets the derivative times in seconds for error signals marked "+" and "-".

It can be set between **0** and **2500**. If "0" is selected, derivative operation is not performed.

This is not monitored when **CONTROL TYPE** is **OFF**.

◆ **HYSTERESIS**

Hysteresis Value

It determines the hysteresis value during **ON-OFF** control and Auto-Tune operation.

It can be set between **0.0** ile **999.9** (°C).

3.5.7. DEVICE Page

◆ **ADMIN**

The Administrator Password Set Value can be set between **0** and **9999**.

If **LOGIN** is selected while in the **MAIN MENU** screen, the **PASSWORD** screen opens.

The name of the operator logging in with the password is displayed on the **MAIN MENU** screen.

◆ **OPERATOR 1, OPERATOR 2, OPERATOR 3**

The Operator Password Values

It can be between **0** ile **9999**.

◆ **OPERATOR ACCESS 1, OPERATOR ACCESS 2, OPERATOR ACCESS 3**

Operator Parameter Setting Permissions

0-NONE,

1-SV AND OUT, SV and OUT values on operator pages

2-ALARM SETS, ALARM SET values on operator pages

3-PROFILE OP., Profile start stop

4-RESERVED

5-RESERVED

6-RESERVED

7-RESERVED

8-TUNE, TUNE settings page

9-SET, SET settings page

10-ALARM, ALARM settings page

11-OUTPUT, OUTPUT page

12-INPUT, INPUT page

13-PROFILE, Profile and Step page

◆ **LANGUAGE**

Device Language Option

It can be set to **TÜRKÇE** or **ENGLISH**.

◆ **BRIGHTNESS**

Device Display Brightness

It can be adjusted between % **0** ile **100**.

◆ **VERSION**

Software version information is shown.

◆ **C.VERSION**

Controller version information is shown.

◆ **PAGE ACCESS**

Page Access Setting

Desired operator pages can be disabled for monitoring using this parameter. When all operator pages are disabled, **DIGITAL** operator page stays Enabled as default.

ANALOG

DIGITAL

ALARM SET

STATUS

◆ **FACTORY SETTINGS**

It is used to save the parameters as factory settings or to load the parameters previously saved as factory settings.

LOAD : Load the previously saved factory settings.

SAVE : Saves the current settings as the factory value.

3.5.8. PROFILE Page

◆ 9 profile programs can be defined in the device by selecting start (**PROFILE X START**) and end (**PROFILE X END STEP**) step numbers. Please see **STEPS** page for the configuration of steps. **X** can be 1 to 9.

This page is accessible only if the **SETPOINT SOURCE** parameter is set to **PROFILE**.

For the operation of the profiles, please see **3.4.2 DIGITAL Operator Page**.

3.5.9. STEPS Page

This page is active if the **SETPOINT SOURCE** parameter is **PROFILE**.

99 steps can be adjusted for the profile programs. Please refer to the **PROFILE** page for information on how to use and activate these steps. The description of the parameters defined for each step is given below.

◆ **SEGMENT (STEP)**

The number of the step to be adjusted is selected. It can be set between **1** and **99**.

◆ **TIME and SET**

TIME determines the step duration in minutes. The **SV** (Set Value) starts from the end value of the previous step and ramps up or down the **SET** value of the step. As a special case, when the step is the first step of the profile program, the set point is ramps from the current process value.

TIME can be set between **0.0** and **999.9** (min.).

If set as **0.0**, **STEP** is canceled.

SET can be set between **-1999** and **9999**.

3.5.9. STEPS Page

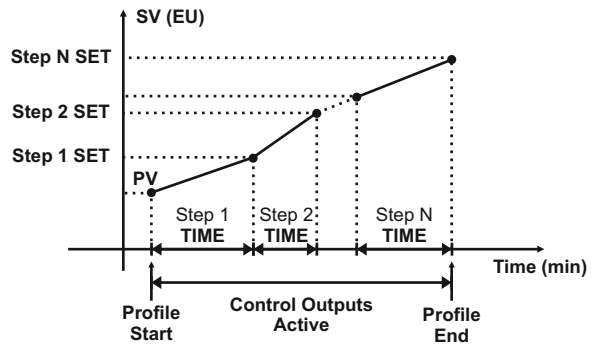

◆ **HYS**

Determines control hysteresis value of the step. If **ALARM O** is set and the **PV** value deviates more than **HYS** value from **SV** value, **ALARM O** becomes activated. **HYS** can be set between **-1999** and **9999**.

◆ **ALARM A, ALARM B, ALARM C, ALARM D, ALARM O,**

ALARM H

The parameters determine whether the corresponding alarms are activated during the step or not. See **Table 4.2** for descriptions of these alarms.

These can be set to **ON** or **OFF**. The parameters **RL1 SOURCE, RL2 SOURCE, RL3 SOURCE, RL4 SOURCE** can be used to assign these alarms to the relay outputs.

4. MODBUS REGISTERS

Table 4.1

Address	Description	Setting Permission	Min.	Max.
0	Status Bits 1 (Table 4.3)	OFF	0	0
1	Status Bits 2 (Table 4.3)	OFF	0	0
2	PV (Process Value)	OFF	0	0
3	SV (Set Point)	OFF	0	0
4	Running Profile Number	OFF	0	0
5	Profile Remaining Repetition	OFF	0	0
6	Running Step Number	OFF	0	0
7	Step End Remaining Time	OFF	0	0
8	DECIMAL POINT	OFF	0	0
9	SET POINT SOURCE	OFF	0	0
10	CONTROL TYPE	OFF	0	0
11	OUT (Output Value)	ON	-1000	1000
12	SV (Set Point)	ON	-1999	9999
13	AUTO TUNE	ON	0	1
14	Profile selection	ON	1	9
15	Profile repeat selection (0=Cont.)	ON	1	9
16-35	see Section 4.1			
36	PROPORTIONAL+	ON	1	9999

Address	Description	Setting Permission	Min.	Max.
37	PROPORTIONAL-	ON	1	9999
38	INTEGRAL+	ON	0	9999
39	DERIVATIVE+	ON	0	2500
40	HYSTERESIS	ON	0	9999
41	SET POINT SOURCE	ON	0	2
42	SET POINT LOW	ON	-1999	9999
43	SET POINT HIGH	ON	-1999	9999
44	SET POINT RAMP	ON	0	600
45	DIGITAL SET 1	ON	-1999	9999
46	DIGITAL SET 2	ON	-1999	9999
47	DIGITAL SET 3	ON	-1999	9999
48	DIGITAL SET 4	ON	-1999	9999
49	PROFILE POWERON	ON	0	4
50	ALARM 1 TYPE	ON	0	6
51	ALARM 1 HYSTERESIS	ON	0	9999
52	ALARM 1 LATCH	ON	0	1
53	ALARM 1 SET	ON	-1999	9999
54	ALARM 2 TYPE	ON	0	6
55	ALARM 2 HYSTERESIS	ON	0	9999
56	ALARM 2 LATCH	ON	0	1

Address	Description	Setting		
		Permission	Min.	Max.
57	ALARM 2 SET	ON	-1999	9999
58	ALARM 3 TYPE	ON	0	6
59	ALARM 3 HYSTERESIS	ON	0	9999
60	ALARM 3 LATCH	ON	0	1
61	ALARM 3 SET	ON	-1999	9999
62	ALARM 4 TYPE	ON	0	6
63	ALARM 4 HYSTERESIS	ON	0	9999
64	ALARM 4 LATCH	ON	0	1
65	ALARM 4 SET	ON	-1999	9999
66	CONTROL TYPE	ON	0	4
67	CONTROL FORM	ON	0	1
68	PWM PERIOD	ON	1	250
69	MANUAL SWITCH	ON	0	1
70	VALVE TRAVEL TIME	ON	10	2500
71	DEAD BAND	ON	1	250
72	SINGLE OUT LOW	ON	0	1000
73	SINGLE OUT HIGH	ON	0	1000
74	SINGLE MNL. RESET	ON	0	1000

Address	Description	Setting		
		Permission	Min.	Max.
75	DOUBLE OUT LOW	ON	-1000	1000
76	DOUBLE OUT HIGH	ON	-1000	1000
77	DOUBLE MNL. RESET	ON	-1000	1000
78	POWER ON ACTION	ON	0	4
79	RL1 SOURCE	ON	0	14
80	RL2 SOURCE	ON	0	14
81	RL3 SOURCE	ON	0	14
82	RL4 SOURCE	ON	0	14
83	AO1 SOURCE	ON	0	3
84	AO2 SOURCE	ON	0	3
85	AO1 RANGE	ON	0	3
86	AO2 RANGE	ON	0	3
87	ANALOG INPUT 1	ON	0	15
88	ANALOG INPUT 2	ON	0	1
89	DECIMAL POINT	ON	1	3
90	ZERO	ON	-1999	9999
91	SPAN	ON	-1999	9999
92	RETRANSMISSION LOW	ON	-1999	9999

Address	Description	Setting		
		Permission	Min.	Max.
93	RETRANSMISSION HIGH	ON	-1999	9999
94	TEMPERATURE UNIT	ON	0	1
95	OFFSET	ON	-1000	1000
96	FILTER	ON	1	100
97	SENSOR BREAK	ON	0	1
98	LANGUAGE	ON	0	1
99	BRIGHTNESS	ON	0	100
100	LINEAR UNIT	ON	0	100
101	MODBUS ADDRESS	ON	1	32
102	BAUD RATE	ON	0	3
103	PARITY	ON	0	2
104	INTEGRAL-	ON	0	2500
105	DERIVATIVE-	ON	0	2500
106	RESERVED	OFF	0	0
107	RESERVED	OFF	0	0
108	RESERVED	OFF	0	0
109	RESERVED	OFF	0	0
110	RESERVED	OFF	0	0

4.1. Profile Programs Modbus Registers

Address	Description	Setting		
		Permission	Min.	Max.
16	Reserve	ON	1	99
17	Reserve	ON	1	99
18	PROFILE1 START STEP	ON	1	99
19	PROFILE1 END STEP	ON	1	99
20	PROFILE2 START STEP	ON	1	99
21	PROFILE2 END STEP	ON	1	99
22	PROFILE3 START STEP	ON	1	99
23	PROFILE3 END STEP	ON	1	99
24	PROFILE4 START STEP	ON	1	99
25	PROFILE4 END STEP	ON	1	99
26	PROFILE5 START STEP	ON	1	99
27	PROFILE5 END STEP	ON	1	99
28	PROFILE6 START STEP	ON	1	99
29	PROFILE6 END STEP	ON	1	99
30	PROFILE7 START STEP	ON	1	99
31	PROFILE7 END STEP	ON	1	99
32	PROFILE8 START STEP	ON	1	99
33	PROFILE8 END STEP	ON	1	99
34	PROFILE9 START STEP	ON	1	99
35	PROFILE9 END STEP	ON	1	99

4.2. Profile Steps Modbus Registers

Address	Description	Setting Permission	Min.	Max.
200+4n	STEP TIME ("0" to cancel step.)	ON	0	9999
201+4n	STEP END SET VALUE	ON	-1999	9999
202+4n	STEP WARNINGS (Table 4.2)	ON	0	63
203+4n	STEP HYSTERESIS VALUE	ON	0	9999

NOTE: The value indicated by "n" in the table corresponds to the Step Number. It can be set between 1 and 99.

Table 4.2

Step Warnings		
Bit	0:OFF	1: ON
0	ALARM A	If the deviation at the end of the step is outside the step hysteresis, waits before proceeding to the next step and gives ALARM A.
1	ALARM B	Gives ALARM B During Step unconditionally.
2	ALARM C	Gives ALARM C During Step unconditionally.
3	ALARM D	Gives ALARM D During Step unconditionally.
4	ALARM O	If the deviation during the step is more than the step hysteresis, holds and gives ALARM O.
5	ALARM H	Holds at the beginning of the step and gives ALARM H.

Table 4.3

Status Bits 1		Status Bits 2	
Bit	Description (for 1)	Bit	Description (for 1)
0	1.Relay (RL1) Energized	0	Digital Input 1
1	2.Relay (RL2) Energized	1	Digital Input 2
2	3.Relay (RL3) Energized	2	Digital Input 3
3	4.Relay (RL4) Energized	3	Reserved
4	Sensor Break	4	Alarm 1
5	Sensor OFL	5	Alarm 2
6	Sensor UFL	6	Alarm 3
7	Manual	7	Alarm 4
8	Valve Open	8	Reserved
9	Valve Close	9	Reserved
10	Reserved	10	Reserved
11	Reserved	11	Reserved
12	Reserved	12	Reserved
13	Reserved	13	Reserved
14	Reserved	14	Reserved
15	Reserved	15	Reserved

Table 4.4

Address	Permission	Description	0 (Reset)	1 (Set)
0	ON	Manual/Auto	Auto	Manual
1	ON	Valve Open		Open
2	ON	Valve Close		Close
3	ON	Profile Start/Stop	Stop	Start
4	ON	Profile Continue/Hold	Continue	Hold