



E-48P Series Universal Advanced Digital Controllers Quick Start Guide

Manufacturer / Technical Support

Elimko Elektronik İmalat ve Kontrol Ltd. Şti.
8. Cadde 21. Sokak No:16 Emek 06510 Ankara / TÜRKİYE
Telefon: + 90 312 212 64 50 Faks: + 90 312 212 41 43
www.elimko.com.tr • e-mail:elimko@elimko.com.tr



4. WARNINGS

E-48P controller is designed for panel mounting and should be used in an industrial environment.



- The package of E-48P controller contains; Controller, 2 pieces of mounting clamps, User manual and Guarantee certificate.
- After opening the package, please check the contents with the above list. If the delivered product is wrong type, any item is missing or there are visible defects, contact the vendor from which you purchased the product.
- Before installing and operating the controller, please read the user manual thoroughly.
- The installation and configuration of the controller must only be performed by a person qualified in instrumentation.
- Keep the unit away from flammable gases, that could cause explosion.
- Do not use alcohol or other solvents to clean the controller. Use a clean cloth soaked in water tightly squeezed to gently wipe the outer surface of the controller.
- It is not used in medical applications.

1. DESCRIPTION

E-48P Series universal process controllers are industrial devices at 48x48 mm IEC/TR 60668 dimensions designed using new generation microcontrollers with on/off, PID and other control forms, where inputs and outputs can be easily programmed by the user.

In E-48P Series controllers, the set value and measured value can be displayed from -1999 to 9999 on two 4-digit displays; general purpose inputs (T/C, R/T, mV, mA) can be programmed.

2. DIMENSIONS and PANEL CUT-OUT

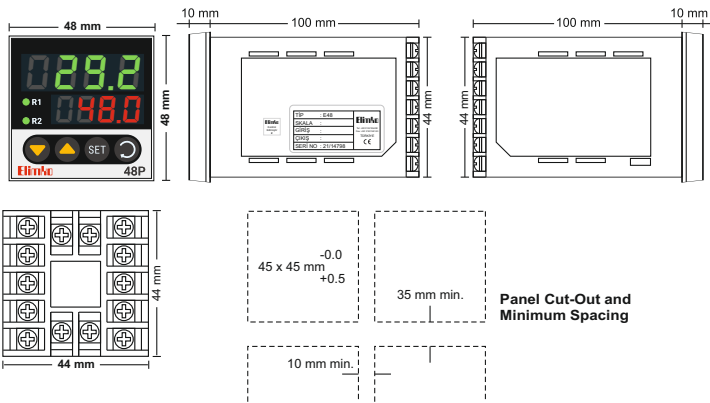

3. CONNECTION DIAGRAM

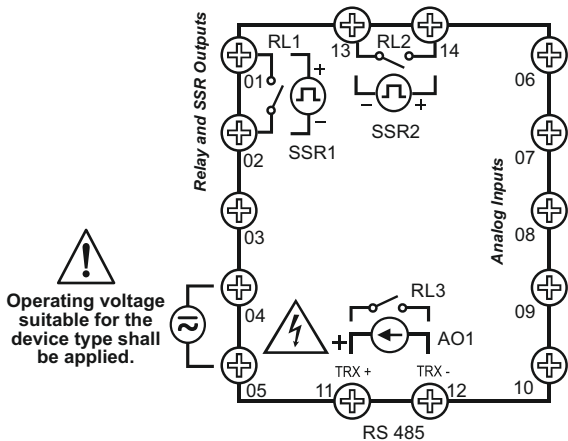

1st and 2nd control outputs can be selected as either Relay (RL1, RL2) or SSR (SSR1, SSR2).

Only one of analog output (AO1) and RS-485 can be selected.

Analog output (AO1) mA or 0-10 V DC can be selected.

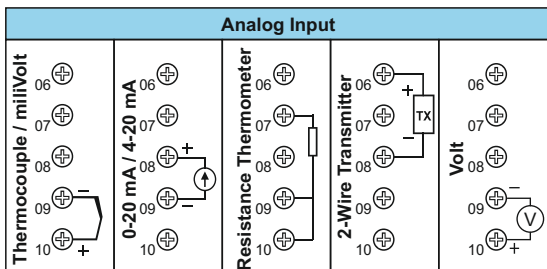

EU DIRECTIVE COMPLIANCE

Low Voltage Directive EN 61010-1
EMC Directive EN 61326-1



TS EN ISO 9001
Quality Management System Certificate

5. TYPE CODING

E-48 Series Universal Advanced Controller

E-48 - W - X - Y - Z

Relay Outputs

- None
- 1 relay (RL1)
- 2 relays (RL1, RL2)
- 3 relays (RL1, RL2, RL3)
- 1 SSR (SSR1)
- 1 SSR (SSR1) + 1 relay (RL2)
- 1 SSR (SSR1) + 2 relay (RL2, RL3)
- 2 SSR (SSR1, SSR2)
- 2 SSR (SSR1, SSR2) + 1 relay (RL3)

0
1
2
3
4
5
6
7
8

Analog Outputs *

- None
- 0-20 / 4-20 mA (AO1)
- 0-10 V DC (AO1)

0
1
2

Communication

- None
- RS-485 **

0
1

Operating Voltage

- 85-265 V AC / 85-375 V DC
- 20-60 V AC / 20-60 V DC

0
1

* Only one of the relay 3 output, Analogue output and RS485 Modbus options can be coded. For example, only one of the (X) and (Y) options can be coded as 1. Similarly, when the (W) option includes Relay 3 (W=3, 6 or 8) X and Y 1 cannot be selected.

** When E-48 Series controllers are ordered with communication, the E-IB-11 USB-RS485 converter can be used for PC connection. There are various control and monitoring software provided by Elimko.

6. TECHNICAL SPECIFICATIONS

Parameter	Description
Control Type	On/Off, PID, Heat/Cool, Floating and Feedback Control of Valves
Operating Voltage	20..60 V AC / 20..60 V DC or 85..265 V AC / 85..375 V DC
Relays / SSR	2 pieces SPST - NO 250 V AC 5A relays or 24 V DC 25 mA (SSR) drives
Dimensions (mm)	48 (Length) x 48 (Height) x 100 (Width)
Panel Cut-Out (mm)	45 (Length) x 45 (Height)
Analog Output	1 x 0..20 / 4..20 mA or 0..10 V DC optional
Analog Input	Universal (Note 1),
Communication (RS-485)	Available (RS-485)
Digital Input	None
Valve Feedback	None
Transmitter Supply	Available
Weight	115 g
Power Consumption	Max. 7 W (10 VA)
Operating Temperature	- 10 °C ... 55 °C
Storage Temperature	- 25 °C ... 65 °C
Memory	Maks. 100.000 write
Protection Class	IP-65 Front Panel, IP-20 Rear Case

Notes:

(1) Universal Input :

- Thermocouple : B, E, J, K, L, N, R, S, T, U
- Resistance Thermometer : Pt-100
- Current : 0-20 mA, 4-20 mA (Linear)
- Voltage : 0-50 mV, 0-1 V, 0.2- 1 V (Linear), 0-10 V DC, must be specified in the order.
- Resolution : 16 bit
- Accuracy : Thermocouple, Max. ±1.0 °C (Conversion and CJC error)
Resistance Thermometer, Max. ±0.5 °C (Conversion and wire resistance compensation)
Linear Input, Max. % 0.1

7. PARAMETER TABLE

Description		Min	Maks	Unit
INPUT SETTINGS GEnF	inP 1	Table 1		
	dP	0	3	
	SLo	-199.9	999.9	EU
	SHi	-199.9	999.9	EU
	UnIt	oC	oF	
	oFSt	-100.0	100.0	EU
	FLtF	1	15	s
	Snbr	Lo	Hi	
	RdS	1	127	
	bRtd	[48, 96, 192, 384 kbaud]		
PrEtY	[nonE, odd EvEn]			

CONTROL SET SETTINGS SEtP	SPSr	Table 2		
	SPLL	-199.9	SPHL	EU
	SPHL	999.9		EU
	SPrr	oFF	60.0	EU/min
	S-1	SPLL	SPHL	EU
	t-1	oFF	999.9	min
	S-2	SPLL	SPHL	EU
	t-2	oFF	999.9	min
	S-3	SPLL	SPHL	EU
	t-3	oFF	999.9	min

ALARM SETTINGS REnF	R1tP	Table 3		
	R1SP	-199.9	999.9	EU
	R1HY	0.0	999.9	EU
	R1Lt	d5b	Enb	
	R2tP	Table 3		
	R2SP	-199.9	999.9	EU
	R2HY	0.0	999.9	EU
	R2Lt	d5b	Enb	
	R3tP	Table 3		
	R3SP	-199.9	999.9	EU
	R3HY	0.0	999.9	EU
	R3Lt	d5b	Enb	

OUTPUTS oEnF	CLtP	Table 4		
	CFrñ	dIr	rEu	
	CPrd	1	250	s
	ñnPr	d5b	Enb	
	trtñ	10	2500	s
	dbnd	0.1	25.0	%
	oLL	0.0	oHL	%
	oHL	oLL	100.0	%
	oñr	oLL	oHL	%
	PonC	0	4	
	trLL	-199.9	trHL	EU
	trHL	trLL	999.9	EU
	rLid	Table 5		
	rL2d	Table 5		
	rL3d	Table 5		
RoId	Table 6			
RoIr	Table 7.1 ve Table 7.2			

PID SETTINGS LUnE	Rt	oFF	on	
	PId	Std	RdW	
	Pb-1	0.1	999.9	EU
	Pb-2	0.1	999.9	EU
	ItH	oFF	9999	s
	ItL	oFF	9999	s
	dEtH	oFF	2500	s
	dEtL	oFF	2500	s
	HY5	0.0	999.9	EU

SECURITY PrEtL	SCod	0	9999	
	dPrL	0	9	
	RPrL	0	9	
	FCSt	[oFF, LoRd, SRuE, dFLt]		

8. ACCESSING PARAMETERS

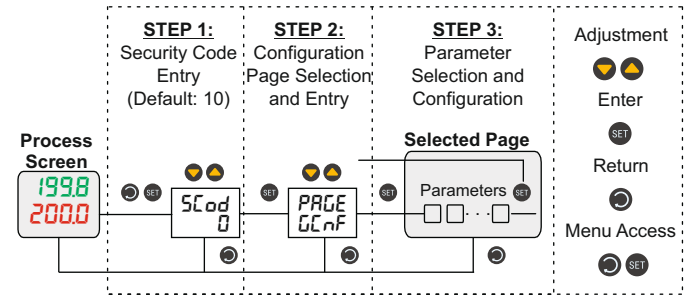

9. APPLICATION EXAMPLES

- 1) Input: Pt-100 Relay / Alarm1: 50 °C Low, Relay2 / Alarm2: 55 °C High
AO1: 4-20 mA PID Control Output

inP 1	R1tP	R1SP	R2tP	R2SP	CLtP	rLid	rL2d	RoId	RoIr
Pt	Lo	50.0	Hi	55.0	SLo	RL-1	RL-2	Lo-1	4-20

- 2) Input: TC Type J, Relay1: On-Off Control Output, Relay2 / Alarm2: 350 °C High

inP 1	R2tP	R2SP	CLtP	rLid	rL2d
J	Hi	350.0	SLo	do-1	RL-2

- 3) Input: TC Type K, Profile Control (Ramp up to 400°C in 10 minutes and wait for 60 minutes),
Relay1: PID Control Output, AO1: Retransmission Output (4-20 mA, 0-1200 °C)

inP 1	SPSr	S-1	t-1	S-2	t-2	CLtP	trLL	trHL	rLid	rL2d	RoId	RoIr
K	PrFL	400	10.0	400	60.0	SLo	0	1200	Lo-1	RL-2	PuTr	4-20

Important Note:

In E-48P series devices, the energization status of Relay 3th is indicated differently from Relays 1st and 2nd. When Relay 1st and Relay 2nd are energized, the R1 and R2 LED indicators on the front panel turn on. When Relay 3th is energized, the decimal point located at the lower right corner of the rightmost digit on the upper display (where the process value is shown) blinks, indicating that the relay is active.

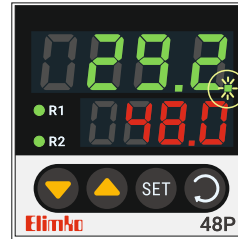

It blinks when Relay 3th is energized.

Table 1. Input Type Options

b	Type B Thermocouple
E	Type E Thermocouple
J	Type J Thermocouple
K	Type K Thermocouple
L	Type L Thermocouple
n	Type N Thermocouple
r	Type R Thermocouple
S	Type S Thermocouple
t	Type T Thermocouple
U	Type U Thermocouple
Pt	Pt-100
0-20	0-20 mA
4-20	4-20 mA
0-50	0-50 mV
0.0-1	0-1 V
0.2-1	0.2-1 V
0-10	0-10 V (*)
2-10	2-10 V (*)

(*) Custom specified volt input

Table 2. Control Set Options

inL	Internal adjustment with keys
PrFL	With Profile Control

Table 3. Alarm Options

oFF	Off
Lo	Low Alarm
Hi	High Alarm
LoD	Low Deviation
HiD	High Deviation
LoB	Band Alarm (In)
HiB	Band Alarm (Out)

Table 4. Control Type Options

oFF	No Control
SLo	Single (Heat)
dLo	Double (Heat/Cool)
bnd	Floating Control of Valve

Table 5. Relay Output Options

Lo-1	PID + (Heating)
Lo-2	PID - (Cooling)
do-1	On-Off + (Heating)
do-2	On-Off - (Cooling)
RL-1	Alarm 1
RL-2	Alarm 2
RL-3	Alarm 3
RL-4	Alarm 4

Table 6. Analog Output Options

Lo-1	PID + (Heating)
Lo-2	PID - (Cooling)
PuTr	Process Value
SPtR	Control Set Value

Table 7.1. Analog Output Range

0-20	0-20 mA
20-0	20-0 mA
4-20	4-20 mA
20-4	20-4 mA

Table 7.2. Analog Output Range

0-10	0-10 V
10-0	10-0 V
2-10	2-10 V
10-2	10-2 V

For detailed information, you can access the comprehensive user manual of the device under the heading "User Manuals" at www.elimko.com.tr. You can also use the QR Code on the front for this.