

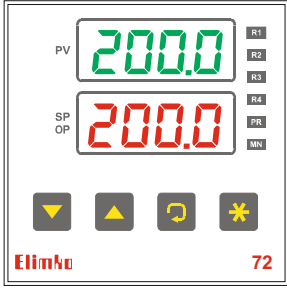

E-72 Series Universal Advanced Controller Quick Start Guide

Manufacturer / Technical Support :
Elimko Elektronik İmalat ve Kontrol Ltd. Şti.
ASO 2. Organize Sanayi Bölgesi Alçı OSB Mahallesi
2001. Cad. No:14 Temelli 06909 Ankara / TÜRKİYE
Tel: +90 312 212 64 50 (Pbx) • Fax: +90 312 212 41 43
E-mail: elimko@elimko.com.tr • www.elimko.com.tr



1. DESCRIPTION

E-72 Series general purpose process controllers are industrial devices in 1/8 DIN (72x72 mm IEC/TR 60668) dimensions designed by using new generation microcontrollers with on/off, PID and other control forms. Inputs and outputs can be easily programmed by the user.

In E-94 Series controllers, set value and measured value can be displayed from -1999 to 9999 on two 4-digit displays and general purpose inputs (T/C, R/T, mV, mA) can be programmed.

2. DIMENSIONS and PANEL CUT-OUT

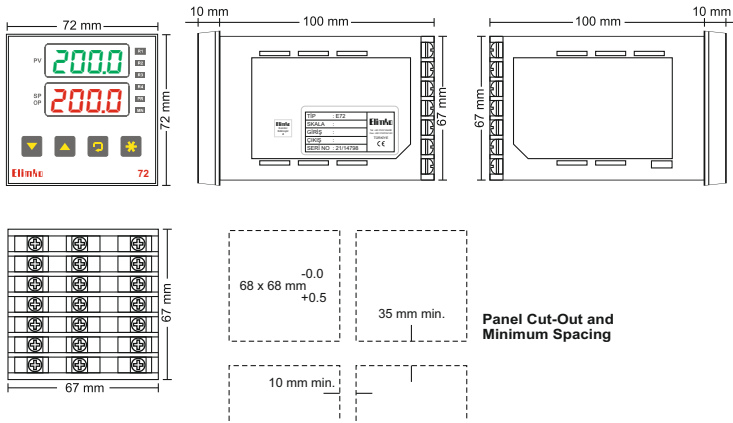

3. CONNECTION DIAGRAM

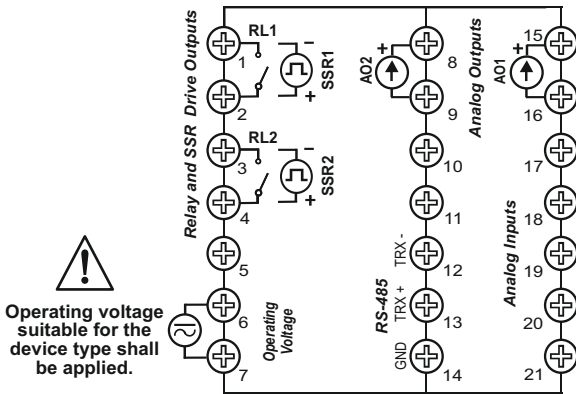

1st and 2nd control outputs can be selected as either Relay (RL1, RL2) or SSR (SSR1, SSR2).

Analog output (AO1) mA or 0-10 V DC can be selected.

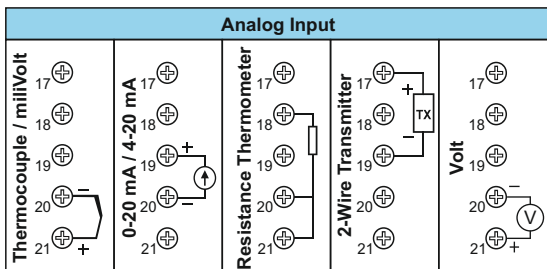

4. WARNINGS

E-72 controller is designed for panel mounting and should be used in an industrial environment.



- The package of E-72 controller contains; Controller, 2 pieces of mounting clamps, User manual and Guarantee certificate.
- After opening the package, please check the contents with the above list. If the delivered product is wrong type, any item is missing or there are visible defects, contact the vendor from which you purchased the product.
- Before installing and operating the controller, please read the user manual thoroughly.
- The installation and configuration of the controller must only be performed by a person qualified in instrumentation.
- Keep the unit away from flammable gases, that could cause explosion.
- Do not use alcohol or other solvents to clean the controller. Use a clean cloth soaked in water tightly squeezed to gently wipe the outer surface of the controller.
- It is not used in medical applications.

EU DIRECTIVE COMPLIANCE

Low Voltage Directive
EN 61010-1
EMC Directive
EN 61326-1



TS EN ISO 9001
Quality Management System Certificate

5. TYPE CODING

E-72 Series Universal Advanced Controller

E-72 - W - X - Y - Z

Relay Outputs

- None
- 1 relay (RL1)
- 2 relays (RL1, RL2)
- 1 SSR (SSR1)
- 1 SSR (SSR1) + 1 relay (RL2)
- 2 SSR (SSR1, SSR2)

0
1
2
3
4
5

Analog Outputs *

- None
- 1 x 0-20 / 4-20 mA (AO1)
- 2 x 0-20 / 4-20 mA (AO1, AO2) *
- 1 x 0-10 V DC (AO1)
- 2 x 0-10 V DC (AO1, AO2) *
- 1 x 0-20 / 4-20 mA (AO1) + 1 x 0-10 V DC (AO2)

0
1
2
3
4
5

Communication

- None
- RS-485 **

0
1

Operating Voltage

- 85-265 V AC / 85-375 V DC
- 20-60 V AC / 20-60 V DC

0
1

* Analog outputs are isolated from each other.

** When E-72 Series controllers are ordered with communication, the E-IB-11 USB-RS485 converter can be used for PC connection. There are various control and monitoring software provided by Elimko.

6. TECHNICAL SPECIFICATIONS

Parameter	Description
Control Type	On/Off, PID, Heat/Cool, Floating and Feedback Control of Valves
Operating Voltage	20..60 V AC / 20..60 V DC or 85..265 V AC / 85..375 V DC
Relays / SSR	2 pieces SPST - NO 250 V AC 5A relays or 24 V DC 25 mA (SSR) drives
Dimensions (mm)	72 (Length) x 72 (Height) x 100 (Width)
Panel Cut-Out (mm)	68 (Length) x 68 (Height)
Analog Output	2 x 0..20 / 4..20 mA (Max. Load 600 Ohm) or 0..10 V DC optional
Analog Input	Universal (Note 1),
Communication (RS-485)	Available (Optional)
Digital Input	None
Valve Feedback	None
Transmitter Supply	Available
Weight	232 g
Power Consumption	Max. 7 W (10 VA)
Operating Temperature	- 10 °C ... 55 °C
Storage Temperature	- 25 °C ... 65 °C
Memory	Maks. 100.000 write
Protection Class	IP-65 Front Panel, IP-20 Rear Case

Notes:

(1) Universal Input :

- Thermocouple : B, E, J, K, L, N, R, S, T, U
- Resistance Thermometer : Pt-100
- Current : 0-20 mA, 4-20 mA (Linear)
- Voltage : 0-50 mV, 0-1 V, 0.2- 1 V (Linear), 0-10 V DC, must be specified in the order.
- Resolution : 16 bit
- Accuracy : Thermocouple, Max. ±1.0 °C (Conversion and CJC error)
Resistance Thermometer, Max. ±0.5 °C (Conversion and wire resistance compensation)
Linear Input, Max. % 0.1

7. PARAMETER TABLE

		Description	Min	Maks	Unit	
INPUT SETTINGS	Gcnf	inp1	Analog Input 1 Type			Table 1
		dP	Decimal Point			0 3
		SLo	Analog Input 1 Linear Scale Lower Value			-199.9 999.9 EU
		SCH	Analog Input 1 Linear Scale Upper Value			-199.9 999.9 EU
		UnIt	Temperature Unit			°C °F
		oFSt	Analog Input 1 Offset Value			-100.0 100.0 EU
		FLtR	Analog Input 1 Filter			1 15 s
		Snbr	Analog Input 1 Sensor Broken Behaviour			Lo Hi
		RdS	Modbus Address			1 127
		bRd	Modbus Baud Rate [48, 96, 192, 384 kbaud]			48 384
PrLy	Modbus Parity [nonE, odd, EvEn]					

		Description	Min	Maks	Unit	
CONTROL SET SETTINGS	SETP	SPSr	Control Set Point Source			Table 2
		SPLL	Control Set Point Lower Limit			-199.9 5PHL EU
		SPHL	Control Set Point Upper Limit			5PLL 999.9 EU
		SPRr	Control Set Point Ramping Rate			oFF 60.0 EU/min
		S-1	1. Step Set Value			5PLL 5PHL EU
		t-1	1. Step Time			oFF 999.9 min
		S-2	2. Step Set Value			5PLL 5PHL EU
		t-2	2. Step Time			oFF 999.9 min
S-3	3. Step Set Value			5PLL 5PHL EU		
t-3	3. Step Time			oFF 999.9 min		

		Description	Min	Maks	Unit	
ALARM SETTINGS	RLnf	R1tP	Alarm 1 Type			Table 3
		R1SP	Alarm 1 Set Point			-199.9 999.9 EU
		R1HY	Alarm 1 Hysteresis			0.0 999.9 EU
		R1Lt	Alarm 1 Lock			d5b Enb
		R2tP	Alarm 2 Type			Table 3
		R2SP	Alarm 2 Set Point			-199.9 999.9 EU
		R2HY	Alarm 2 Hysteresis			0.0 999.9 EU
R2Lt	Alarm 2 Lock			d5b Enb		

		Description	Min	Maks	Unit	
OUTPUTS	oLnf	CLYP	Control Type			Table 4
		CFrn	Control Form [dir, rEv]			dir rEv
		CPrd	Control Period			1 250 s
		nnPr	Manual Mode Selection			d5b Enb
		trtn	Floating Control Valve Travel Time			10 2500 s
		dbnd	Dead Band			0.1 25.0 %
		oLL	Control Output Lower Limit			0.0 oHL %
		oHL	Control Output Upper Limit			oLL 100.0 %
		oNr	Control Output Manual Reset			oLL oHL %
		Paon	PID Power On Behaviour			0 4
		trLL	Retransmission Scale Lower Value			-199.9 trHL EU
		trHL	Retransmission Scale Upper Value			trLL 999.9 EU
		rLid	Relay 1 Function			Table 5
		rL2d	Relay 2 Function			Table 5
Ro id	Analog Output 1 Function			Table 6		
Ro ir	Analog Output 1 Type			Table 7.1 ve Table 7.2		
Ro2d	Analog Output 2 Function			Table 6		
Ro2r	Analog Output 2 Type			Table 7.1 ve Table 7.2		

		Description	Min	Maks	Unit	
PID SETTINGS	LInE	Rt	PID Auto Tune			oFF on
		P id	PID Parameter Type			Std Rdu
		Pb+	Proportional Band +			0.1 999.9 EU
		Pb-	Proportional Band -			0.1 999.9 EU
		ItH	Integral Time +			oFF 9999 s
		ItL	Integral Time -			oFF 9999 s
		dH	Derivative Time +			oFF 2500 s
		dL	Derivative Time -			oFF 2500 s
HY5	Hysteresis			0.0 999.9 EU		

		Description	Min	Maks	Unit	
SECURITY	PrLc	SLod	Security Code			0 9999
		dPrL	Parameter Access Level			0 9
		RPrL	Parameter Setting Level			0 9
		FLSt	Factory Settings [oFF, LoRd, SRuE, dFLt]			

8. ACCESSING PARAMETERS

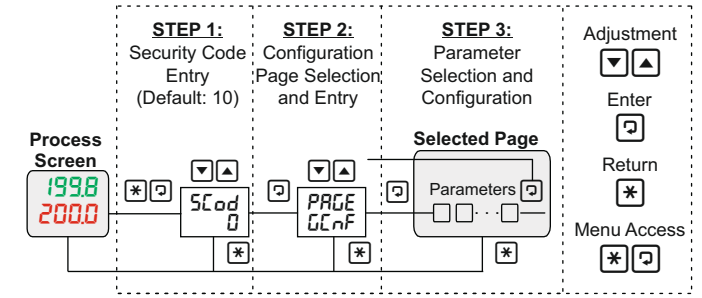

9. APPLICATION EXAMPLES

1) Input: Pt-100 Relay / Alarm1: 50 °C Low, Relay2 / Alarm2: 55 °C High
AO1: 4-20 mA PID Control Output

inp1	R1tP	R1SP	R2tP	R2SP	CLYP	rL id	rL2d	Ro id	Ro ir
Pt	Lo	50.0	Hi	55.0	SLo	RL-1	RL-2	Co-1	4-20

2) Input: TC Type J, Relay1: On-Off Control Output, Relay2 / Alarm2: 350 °C High

inp1	R2tP	R2SP	CLYP	rL id	rL2d
J	Hi	350.0	SLo	do-1	RL-2

3) Input: TC Type K, Profile Control (Ramp up to 400°C in 10 minutes and wait for 60 minutes),
Relay1: PID Control Output, AO1: Retransmission Output (4-20 mA, 0-1200 °C)

inp1	SPSr	S-1	t-1	S-2	t-2	CLYP	trLL	trHL	rL id	rL2d	Ro id	Ro ir
K	PrFL	400	10.0	400	60.0	SLo	0	1200	Co-1	RL-2	PuTr	4-20

Table 1. Input Type Options

b	Type B Thermocouple
E	Type E Thermocouple
J	Type J Thermocouple
K	Type K Thermocouple
L	Type L Thermocouple
N	Type N Thermocouple
R	Type R Thermocouple
S	Type S Thermocouple
T	Type T Thermocouple
U	Type U Thermocouple
Pt	Pt-100
0-20	0-20 mA
4-20	4-20 mA
0-50	0-50 mV
00-1	0-1 V
02-1	0.2-1 V
0-10	0-10 V (*)
2-10	2-10 V (*)

(*) Custom specified volt input

Table 2. Control Set Options

InL	Internal adjustment with keys
PrFL	With Profile Control

Table 3. Alarm Options

oFF	Off
Lo	Low Alarm
Hi	High Alarm
LoD	Low Deviation
HiD	High Deviation
LoB	Band Alarm (In)
HiB	Band Alarm (Out)

Table 4. Control Type Options

oFF	No Control
SLo	Single (Heat)
dLo	Double (Heat/Cool)
bnd	Floating Control of Valve

Table 5. Relay Output Options

Co-1	PID + (Heating)
Co-2	PID - (Cooling)
do-1	On-Off + (Heating)
do-2	On-Off - (Cooling)
RL-1	Alarm 1
RL-2	Alarm 2
RL-3	Alarm 3
RL-4	Alarm 4

Table 6. Analog Output Options

Co-1	PID + (Heating)
Co-2	PID - (Cooling)
PuTr	Process Value
SPTr	Control Set Value

Table 7.1. Analog Output Range

0-20	0-20 mA
20-0	20-0 mA
4-20	4-20 mA
20-4	20-4 mA

Table 7.2. Analog Output Range

0-10	0-10 V
10-0	10-0 V
2-10	2-10 V
10-2	10-2 V

For detailed information, you can access the comprehensive user manual of the device under the heading "User Manuals" at www.elimko.com.tr. You can also use the QR Code on the front for this.