

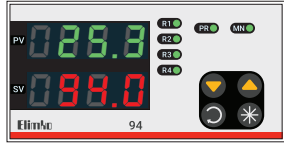

E-94 Series Universal Advanced Controller Quick Start Guide



Manufacturer / Technical Support :

Elimko Elektronik İmalat ve Kontrol Ltd. Şti.
ASO 2. Organize Sanayi Bölgesi Alcı OSB Mahallesi
2001. Cad. No:14 Temelli 06909 Ankara / TÜRKİYE
Tel: +90 312 212 64 50 (Pbx) • Fax: +90 312 212 41 43
E-mail: elimko@elimko.com.tr • www.elimko.com.tr

1. DESCRIPTION

E-94 Series general purpose process controllers are industrial devices in 1/8 DIN (96x48 mm IEC/TR 60668) dimensions designed by using new generation microcontrollers with on/off, PID and other control forms. Inputs and outputs can be easily programmed by the user.

In E-94 Series controllers, set value and measured value can be displayed from -1999 to 9999 on two 4-digit displays and general purpose inputs (T/C, R/T, mV, mA) can be programmed.

2. DIMENSIONS and PANEL CUT-OUT

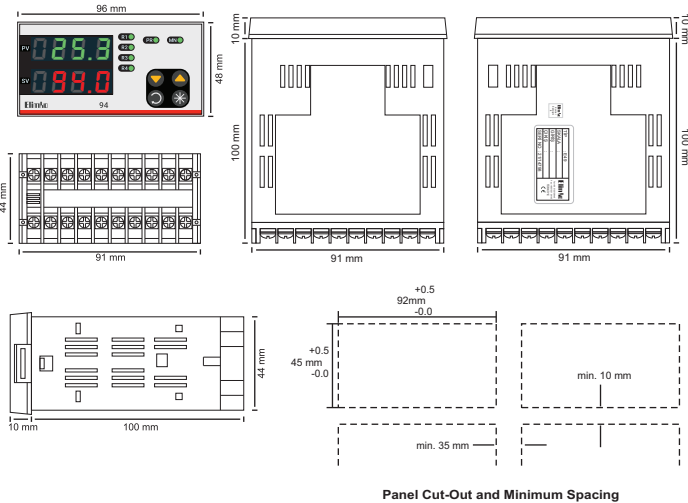

3. CONNECTION DIAGRAM

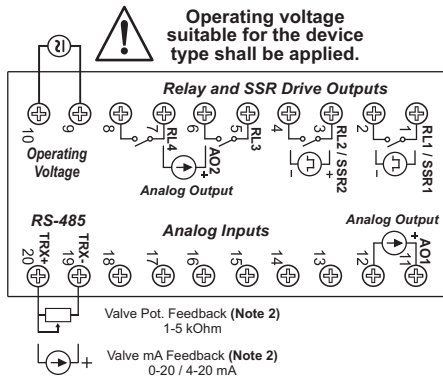

1st and 2nd control outputs can be selected as either Relay (RL1, RL2) or SSR (SSR1, SSR2).
Analog outputs (AO1, AO2) mA or 0-10 V DC can be selected.
If the AO2 option is selected, RL3 and RL4 cannot be given.
Controllers with RS-485 do not have a Valve Feedback input.

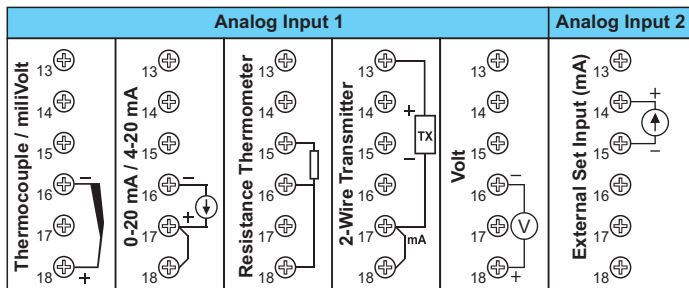

4. WARNINGS

E-94 controller is designed for panel mounting and should be used in an industrial environment.

- The package of E-94 controller contains; Controller, 2 pieces of mounting clamps, User manual and Guarantee certificate.
- After opening the package, please check the contents with the above list. If the delivered product is wrong type, any item is missing or there are visible defects, contact the vendor from which you purchased the product.
- Before installing and operating the controller, please read the user manual thoroughly.
- The installation and configuration of the controller must only be performed by a person qualified in instrumentation.
- Keep the unit away from flammable gases, that could cause explosion.
- Do not use alcohol or other solvents to clean the controller. Use a clean cloth soaked in water tightly squeezed to gently wipe the outer surface of the controller.
- It is not used in medical applications.



EU DIRECTIVE COMPLIANCE

Low Voltage Directive: EN 61010-1
EMC Directive: EN 61326-1



TS EN ISO 9001
Quality Management System Certificate

5. TYPE CODING

E-94 Series Universal Advanced Controller

E-94 - W - X - Y - Z

Relay Outputs

- 2 relays (RL1, RL2)
- 3 relays (RL1, RL2, RL3)
- 4 relays (RL1, RL2, RL3, RL4)
- 1 SSR (SSR1) + 1 relay (RL2)
- 1 SSR (SSR1) + 2 relays (RL2, RL3)
- 1 SSR (SSR1) + 3 relays (RL2, RL3, RL4)
- 2 SSR (SSR1, SSR2) + 1 relay (RL3)
- 2 SSR (SSR1, SSR2) + 2 relays (RL3, RL4)

Analog Outputs

- None
- 1 x 0-20 / 4-20 mA (AO1)
- 2 x 0-20 / 4-20 mA (AO1, AO2)
- 1 x 0-10 V DC (AO1)
- 2 x 0-10 V DC (AO1, AO2)

Communication *

- None
- RS-485 **

Operating Voltage

- 85-265 V AC / 85-375 V DC
- 20-60 V AC / 20-60 V DC

* When E-94 Series devices are ordered with communication, the E-IB-11 USB-RS485 converter can be used for PC connection. There are various control and monitoring software provided by Elimko.

** Controllers with RS-485 do not have a Valve Feedback input.

6. TECHNICAL SPECIFICATIONS

Parameter	Description
Control Type	On/Off, PID, Heat/Cool, Floating and Feedback Control of Valves
Operating Voltage	20..60 V AC / 20..60 V DC or 85..265 V AC / 85..375 V DC
Relays / SSR	4 x SPST - NO 250 V AC 5 A relays or 24 V DC 25 mA (SSR) drives
Dimensions (mm)	96 (Length) x 48 (Height) x 100 (Width)
Panel Cut-Out (mm)	92 (Length) X 45 (Height)
Analog Output	2 x 0..20 / 4..20 mA or 0..10 V DC optional
Analog Input	Universal (Note 1), 1 x External set point (mA)
Communication (RS-485)	Available (Note 2)
Digital Input	None
Valve Feedback	Available (Note 2)
Transmitter Supply	Available
Weight	220 g
Power Consumption	Max. 7 W (10 VA)
Operating Temperature	-10 °C ... 55 °C
Storage Temperature	-25 °C ... 65 °C
Memory	Max. 100.000 write
Protection Class	IP-65 Front Panel, IP-20 Rear Case

Notes:

(1) Universal Input :

- Thermocouple : B, E, J, K, L, N, R, S, T, U
- Resistance Thermometer : Pt-100
- Current : 0-20 mA, 4-20 mA (Linear)
- Voltage : 0-50 mV, 0-1 V, 0.2- 1 V (Linear), 0-10 V DC, must be specified in the order.
- Resolution : 16 bit
- Accuracy : Thermocouple, Max. ± 1.0 °C (Conversion and CJC error)
Resistance Thermometer, Max. ± 0.5 °C (Conversion and wire resistance compensation)
Linear Input, Max. % 0.1

(2) Valve Feedback are supplied as potentiometer input in standard controllers.

If the feedback type is requested as mA, it must be specified in the order.
Controllers with RS-485 do not have a Valve Feedback input.

7. PARAMETER TABLE

		Description	Min	Maks	Unit	
INPUT SETTINGS	INP	inP1	Analog Input 1 Type			Table 1
		dP	Decimal Point			0 3
		SLo	Analog Input 1 Linear Scale Lower Value			-199.9 999.9 EU
		SCH	Analog Input 1 Linear Scale Upper Value			-199.9 999.9 EU
		UnIt	Temperature Unit			°C °F
		oFSt	Analog Input 1 Offset Value			-100.0 100.0 EU
		FLtR	Analog Input 1 Filter			1 15 s
		Snbr	Analog Input 1 Sensor Broken Behaviour			Lo Hi
		inP2	Analog Input 2 Type			0-20 4-20
		S2Lo	Analog Input 2 Linear Scale Lower Value			-199.9 999.9 EU
		S2Hi	Analog Input 2 Linear Scale Upper Value			-199.9 999.9 EU
		S2br	Analog Input 2 Sensor Broken Behaviour			Lo Hi
		Adr5	Modbus Adress			1 127
		bRUD	Modbus Baud Rate [48, 96, 192, 384 kbaud]			48 384
Prty	Modbus Parity [none, odd, even]					
CONTROL SET SETTINGS	SETP	SP5r	Control Set Point Source			Table 2
		SPLL	Control Set Point Lower Limit			-199.9 5PHL EU
		SPHL	Control Set Point Upper Limit			5PLL 999.9 EU
		SPrr	Control Set Point Ramping Rate			oFF 60.0 EU/min
		S-1	1. Step Set Value			5PLL 5PHL EU
		t-1	1. Step Time			oFF 999.9 min
		S-2	2. Step Set Value			5PLL 5PHL EU
		t-2	2. Step Time			oFF 999.9 min
		S-3	3. Step Set Value			5PLL 5PHL EU
		t-3	3. Step Time			oFF 999.9 min
ALARM SETTINGS	ALM	R1tP	Alarm 1 Type			Table 3
		R1SP	Alarm 1 Set Point			-199.9 999.9 EU
		R1HY	Alarm 1 Hysteresis			0.0 999.9 EU
		R1Lk	Alarm 1 Lock			d5b Enb
		R2tP	Alarm 2 Type			Table 3
		R2SP	Alarm 2 Set Point			-199.9 999.9 EU
		R2HY	Alarm 2 Hysteresis			0.0 999.9 EU
		R2Lk	Alarm 2 Lock			d5b Enb
		R3tP	Alarm 3 Type			Table 3
		R3SP	Alarm 3 Set Point			-199.9 999.9 EU
		R3HY	Alarm 3 Hysteresis			0.0 999.9 EU
		R3Lk	Alarm 3 Lock			d5b Enb
		R4tP	Alarm 4 Type			Table 3
		R4SP	Alarm 4 Set Point			-199.9 999.9 EU
R4HY	Alarm 4 Hysteresis			0.0 999.9 EU		
R4Lk	Alarm 4 Lock			d5b Enb		
OUTPUT SETTINGS	OUT	CTYP	Control Type			Table 4
		CFrn	Control Form [dir, rev]			dir rev
		CPrd	Control Period			1 250 s
		nnPr	Manual Mode Selection			d5b Enb
		trtn	Floating Control Valve Travel Time			10 2500 s
		dbnd	Dead Band			0.1 25.0 %
		oLL	Control Output Lower Limit			0.0 oHL %
		oHL	Control Output Upper Limit			oLL 100.0 %
		oRr	Control Output Manual Reset			oLL oHL %
		PonC	PID Power On Behaviour			0 4
		trLL	Retransmission Scale Lower Value			-199.9 trHL EU
		trHL	Retransmission Scale Upper Value			trLL 999.9 EU
		rL1d	Relay 1 Function			Table 5
		rL2d	Relay 2 Function			Table 5
		rL3d	Relay 3 Function			Table 5
		rL4d	Relay 4 Function			Table 5
		Ro1d	Analog Output 1 Function			Table 6
		Ro1r	Analog Output 1 Type			Table 7.1 ve Table 7.2
Ro2d	Analog Output 2 Function			Table 6		
Ro2r	Analog Output 2 Type			Table 7.1 ve Table 7.2		
SrvL	Feedback Valve Fully-Closed Position					
SrvH	Feedback Valve Fully-Open Position					
PID SETTINGS	PID	Rt	PID Auto Tune			oFF on
		Pid	PID Parameter Type			Std Rdu
		Pb-1	Proportional Band +			0.1 999.9 EU
		Pb-2	Proportional Band -			0.1 999.9 EU
		ItH	Integral Time +			oFF 9999 s
		ItC	Integral Time -			oFF 9999 s
		dItH	Derivative Time +			oFF 2500 s
		dItC	Derivative Time -			oFF 2500 s
HY5	Hysteresis			0.0 999.9 EU		
SECURITY	SEC	SCod	Security Code			0 9999
		dPrL	Parameter Access Level			0 9
		RPRL	Parameter Setting Level			0 9
		FCSt	Factory Settings [oFF, LoRD, SRuE, dFLt]			

8. ACCESSING PARAMETERS

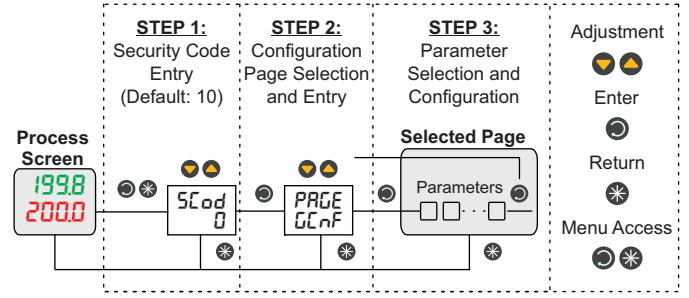

9. APPLICATION EXAMPLES

1) Input: Pt-100 Relay / Alarm1: 50 °C Low, Relay2 / Alarm2: 55 °C High
AO1: 4-20 mA PID Control Output

inP1	R1tP	R1SP	R2tP	R2SP	CTYP	rL1d	rL2d	Ro1d	Ro1r
Pt	Lo	50.0	Hi	55.0	SCo	RL-1	RL-2	Co-1	4-20

2) Input: TC Type J, Relay1: On-Off Control Output, Relay2 / Alarm2: 350 °C High

inP1	R2tP	R2SP	CTYP	rL1d	rL2d
J	Hi	350.0	SCo	do-1	RL-2

3) Input: TC Type K, Profile Control (Ramp up to 400°C in 10 minutes and wait for 60 minutes),
Relay1: PID Control Output, AO1: Retransmission Output (4-20 mA, 0-1200 °C)

inP1	SP5r	S-1	t-1	S-2	t-2	CTYP	trLL	trHL	rL1d	rL2d	Ro1d	Ro1r
K	PrFL	400	10.0	400	60.0	SCo	0	1200	Co-1	RL-2	PuTr	4-20

4) Input: 4-20 mA, Scale: 0-600, External Set Point: 4-20 mA, Scale: 0-600,
Floating Valve Control (Travel Time 30 s), Relay1: Valve Open, Relay2: Valve Close

inP1	SLo	SCH	inP2	S2Lo	S2Hi	CTYP	trtn	rL1d	rL2d
4-20	0.0	600.0	4-20	0.0	600.0	bnd	30	Co-1	Co-2

Table 1. Input Type Options

b	Type B Thermocouple
E	Type E Thermocouple
J	Type J Thermocouple
K	Type K Thermocouple
L	Type L Thermocouple
n	Type N Thermocouple
r	Type R Thermocouple
S	Type S Thermocouple
t	Type T Thermocouple
U	Type U Thermocouple
Pt	Pt-100
0-20	0-20 mA
4-20	4-20 mA
0-50	0-50 mV
0.0-1	0-1 V
0.2-1	0.2-1 V
0-10	0-10 V (*)
2-10	2-10 V (*)

(*) Custom specified volt input

Table 2. Control Set Options

inL	Internal adjustment with keys
PrFL	With Profile Control
ErL	External adjustment with AIN2 external input

Table 3. Alarm Options

oFF	Off
Lo	Low Alarm
Hi	High Alarm
LoD	Low Deviation
HiD	High Deviation
LoB	Band Alarm (In)
HiB	Band Alarm (Out)

Table 4. Control Type Options

oFF	No Control
SCo	Single (Heat)
dCo	Double (Heat/Cool)
bnd	Floating Control of Valve
PFb	Feedback Control of Valve

Table 5. Relay Output Options

Co-1	PID + (Heating)
Co-2	PID - (Cooling)
do-1	On-Off + (Heating)
do-2	On-Off - (Cooling)
RL-1	Alarm 1
RL-2	Alarm 2
RL-3	Alarm 3
RL-4	Alarm 4

Table 6. Analog Output Options

Co-1	PID + (Heating)
Co-2	PID - (Cooling)
PuTr	Process Value
SPTr	Control Set Value

Table 7.1. Analog Output Range

0-20	0-20 mA
20-0	20-0 mA
4-20	4-20 mA
20-4	20-4 mA

Table 7.2. Analog Output Range

0-10	0-10 V
10-0	10-0 V
2-10	2-10 V
10-2	10-2 V

For detailed information, you can access the comprehensive user manual of the device under the heading "User Manuals" at www.elimko.com.tr. You can also use the QR Code on the front for this.