

Manufacturer / Technical Support:
Elimko Elektronik İmalat ve Kontrol Ltd. Şti.
ASO 2. Organize Sanayi Bölgesi Alcı OSB Mahallesi
2001. Cad. No:14 Temelli 06909 Ankara / TÜRKİYE
Tel: +90 312 212 64 50 (Pbx) • Fax: +90 312 212 41 43
E-mail: elimko@elimko.com.tr • www.elimko.com.tr

User Manual

E-680 scanners / data loggers are designed for panel mounting and should be used in an industrial environment.

- The package of E-680 device contains;
 - Device
 - 2 pieces of mounting clamps
 - User manual
 - Guarantee certificate
- After opening the package, please check the contents with the above list. If the delivered product is wrong type, any item is missing or there are visible defects, contact the vendor from which you purchased the product.
- Before installing and operating the device, please read the user manual thoroughly.
- The installation and configuration of the controller must only be performed by a person qualified in instrumentation.
- Keep the unit away from flammable gases, that could cause explosion.
- Do not use alcohol or other solvents to clean the device. Use a clean cloth soaked in water tightly squeezed to gently wipe the outer surface of the device.
- It is not used in medical applications.



EU DIRECTIVE COMPLIANCE

Low Voltage Directive
EN 61010-1
EMC Directive
EN 61326-1

KY-690-0224-1



Index

1. Introduction	3 - 4
1.1. Technical Specifications	5 - 6
1.2. Type Coding	7
1.3. Dimensions	8 - 9
1.4. Panel Mounting	10
2. Usage	11
2.1 Front Panel - Scan Page	11 - 13
2.2. Digital View Page	14 - 15
2.3. Bar Graphic Page	16
2.4. Overview Page	17
3. Menu Pages	18
3.1. Configuration Pages	18
3.2. General Configuration Page	19
3.2.1 Device Page	19 - 20
3.2.2 General Page	21
3.2.3 Analog Output Page	22
3.2.4 Common Relay Page	23
3.2.5 RS-485 Page	24
3.2.6 Ethernet Page	25

Index

3.3. Channel Configuration Page	26
3.3.1 Input Page	26 -28
3.3.2 Virtual Page	29
3.3.3 Alarm1 Page	30
3.3.4 Alarm2 Page	31
3.3.5 Alarm Operation Modes	32
3.4. Calibration Page	33
3.4.1 Analog Input Calibration Page	34
3.4.2 Relay Control Page	35
3.4.3 Common Calibration Page.....	36
3.5. Security Configuration Page	37
3.6. Warning Messages	38
3.7. E-690 Connection Diagrams	39 - 41
3.8. E-690 Jumper Settings	42
3.9. E-690 Communication Connection	43 - 44

1. Introduction

E-690 series industrial recording and control devices complies with IEC/TR 60668 standard with its 96x192 mm front panel. These series has a high brightness and high resolution, 800x480 pixel TFT touch panel and features several analog and digital interfaces. Universal inputs and outputs of the device can be programmed easily by the user. E-690 series indicate measurements from 36 different points on instrument display and determines alarm conditions according to the result of comparison of two set points for each channel. The alarm conditions can be directed to the common alarm relays and / or to the independent relays. The instruments can be connected to an RS-485 / Ethernet communication line and the data can be collected and stored in a centrally located PC.



Figure 1.1. The front panel view of E-690 device



1. Introduction

- 5", 800x480, touch panel TFT screen
- Modbus TCP communication interface with 10/100 Mbit Ethernet
- Standard RS-485 Modbus communication interface
- Semiconductor selector relays with infinite life and high isolation voltage
- Common 2 alarms, independent 18 alarm relay outputs
- 2 adjustable analog outputs (for retransmission)
- Possibility to program each input separately
- Possibility to enter 2 set points for each input
- Possibility to define the alarm type of each set point
- Possibility to define separate fixed bands for each set point
- Possibility to route the output associated with each set point to a common relay or to an independent relay output
- Possibility to program display and scan intervals
- Ability to connect multiple devices (31) to the computer over the same communication line
- Distributed system structure
- Up to 12 channels with pressure and temperature compensated flow calculation
- Arithmetic operations (add, subtract, multiply or divide with a constant) on physical channels

1.1. Technical Specification

Input Types	Thermocouple: B, E, J, K, L, N, R, S, T, U Resistance Thermometer: Pt-100, CUST Voltage: 0-50 mV, 0-1 V, 0.2-1 V 0-10 V (Linear) Current: 0-20 mA, 4-20 mA (Linear)
Alarm Outputs	SPST-NO 250 V AC 3A relay
Display Resolution	5 ", 800x480 pixel, touch panel TFT screen
Accuracy	TC : ±%0.5 of the reading value or ±1°C ±1 digit max. RT : ±%0.5 of the reading value or ±1°C ±1 digit max. Voltage / Current : ±%0.5 FS ±1 digit max.
Analog Digital Converter	16 bit
Digital Analog Converter	12 bit
Input Scan Time	0.2-9.9 sn
Display Scan Time	1-99 sn
Operating Temperature	-10°C, +55°C (14°F, 131°F) (With no condensation or icing)
Storage Temperature	-25°C, +65°C (-13°F, +149°F) (With no condensation or icing)

1.1. Technical Specification

T/C Temperature Compansation	0°C-50°C
Power Supply	85-265 V _{AC} / 85-375 V _{DC} 20-60 V _{AC} / 20-85 V _{DC}
Power Consumption	4 W (7 VA)
Protection Class	IP 66 Front Panel (NEMA 4X) IP 20 Rear Case
Contact Capacity	NA Contact 250 V _{AC} 3 A
Relay Mechanical Life	10.000.000 operation*
Relay Electrical Life	>1.000.000 operation (1/10 yükte)
Memory	EEPROM max. 10 ⁵ writing
Weight	650 gr

*The relay life differs according to the usage configuration. When the relays are old, their contacts could melt or burn out.

1.2. Type Coding

E - 690 - S1 - S2 - S3 - S4 - S5 - S6 - Z

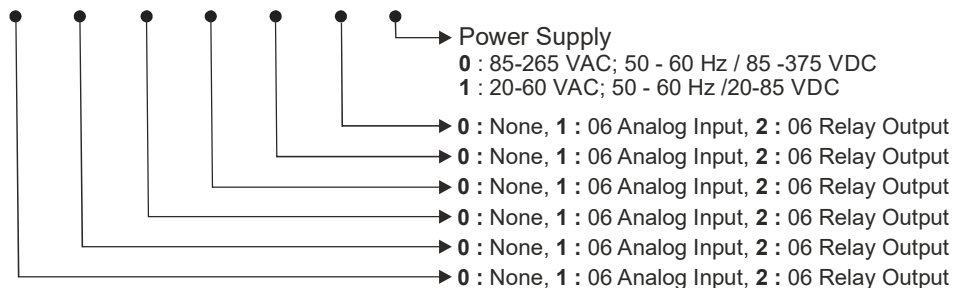

Standart Features:
 - Programmable universal inputs
 - RS-485 Modbus RTU, Ethernet

Coding Example: E-690-1-1-2-0-0-0-0

- Slot 1 and 2 → 06 Analog Input, Slot 3 → 06 Relay Output, other slots empty
 - 85-265 VAC / 85-375 VDC supply

Note: A maximum of 3 06 Relay Output cards can be used.

1.3. Dimensions

Touch Panel

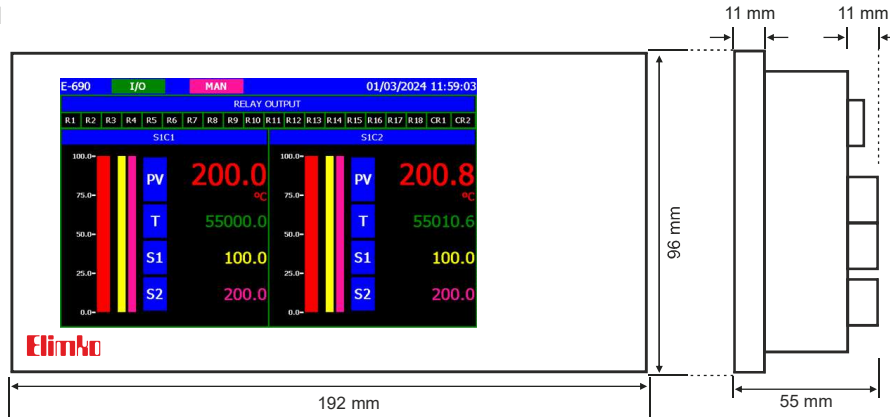

Note: Drawings are not in real scale. Do not use for scaling.

1.3. Dimensions

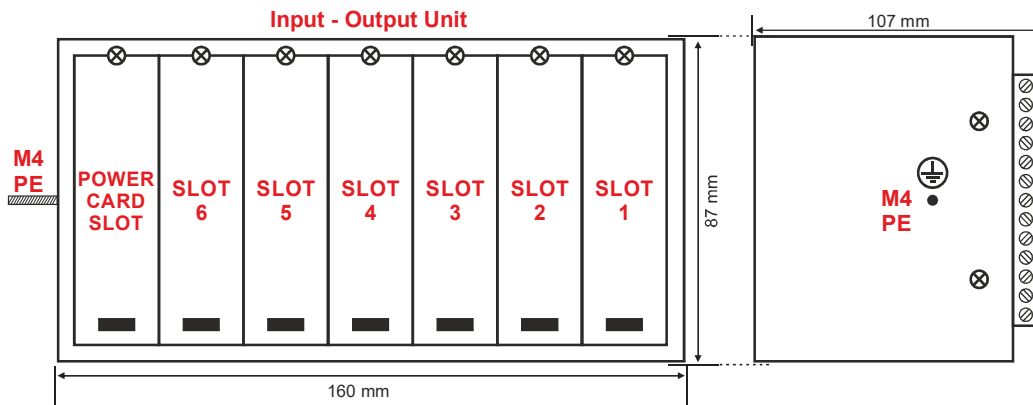

Note: Drawings are not in real scale. Do not use for scaling.

1.4 Panel Mounting

- E-690 controller should be installed inside a suitable grounded metal enclosure (panel). This must prevent the live parts being accessible to human hands and metal tools.
- E-690 controller does not include a power switch. Therefore, the power supply of the controller and power outputs must be wired through the proper fuse or circuit breaker.
- To minimize the pick-up of electrical noise, the wiring of low voltage lines, particularly the sensor inputs should be routed away from the high-current power cables. If this is not possible use screened cables and apply grounding.
- The cables used for powering the controller and the power outputs must conform to the standards IEC 60245 and IEC 60227.

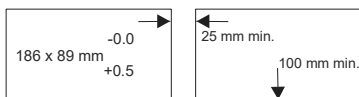

Panel Cutout and Minimum Spacing



- Cut a hole in the panel. (See the figure for overall dimensions.)
- Remove the clamp bracket on the display unit itself and insert the device into the slot from the front of the panel.
- Replace the removed clamp apparatus from the back of the panel fix the indicator.
- Tighten the nuts until the clamps are secured to the board surface.
- The input and output unit of the device to be mounted on a standard DIN rail designed.

2. Usage

2.1 Front Panel - Scan Page

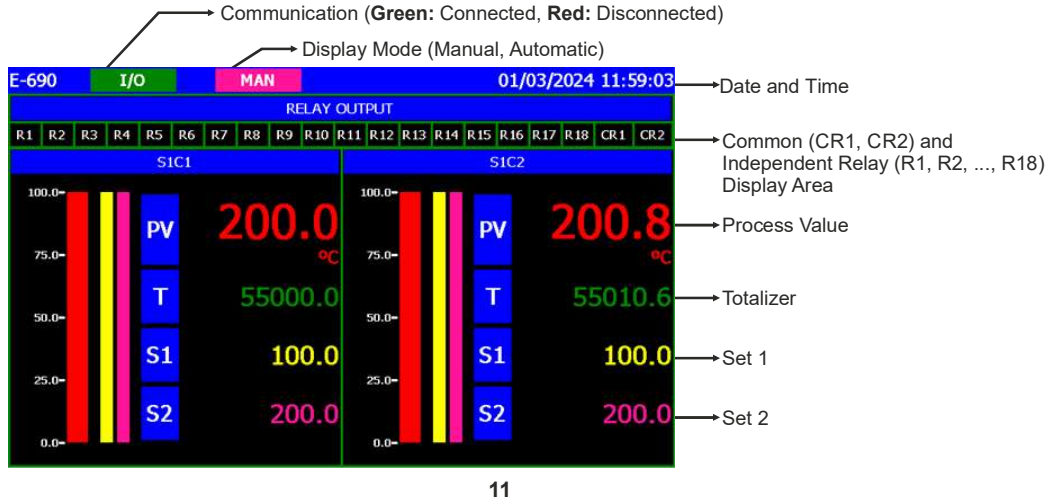

2.1 Front Panel - Scan Page

Operation Buttons:



This button selects any of the **SCAN**, **DIGITAL**, **BAR** and **OVERVIEW** options.



This button selects one of the groups and is active only **DIGITAL** and **BAR** views.



This button allows access to the configuration pages. The factory value of the password is "10".



Active only on the **SCAN** page. Selects the state in which the screen change will be done manually. When manual mode is active, it is shown as **MAN** the screen title. The channels to be displayed on the screen can be changed by the user by scrolling the screen left or right.



Active only on the **SCAN** page. Selects the state in which the screen change will be done automatically. When automatic mode is active, **AUTO** is displayed in the title of the screen. The channels to be displayed on the screen are automatically changed according to the Display Range parameter.

2.1 Front Panel - Scan Page

Operation Buttons:

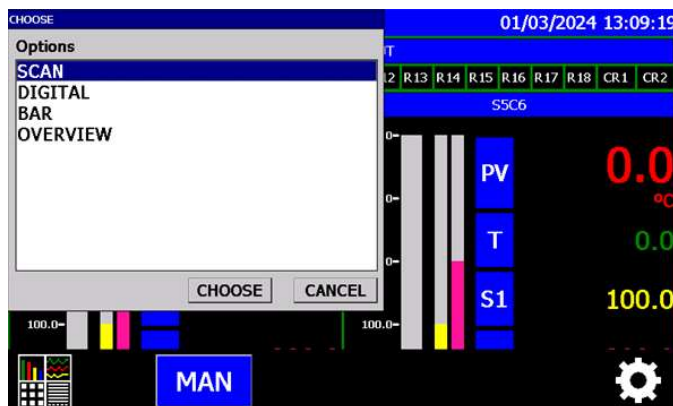

SCREEN when the screen selection key is pressed window opens. **SCAN**, **DIGITAL**, **BAR** or any of **OVERVIEW** can be selected.

2.2. Digital View Page



Process values, totalizer values and alarm conditions of 6 channels belonging to the selected slot can be monitored. The **RESET** button at the top of each channel's own zone resets the totalizer value of the relevant channel. The slot to be monitored can be selected from the **Slot Selection Key** at the bottom or by scrolling the screen to the right or left.

2.2. Digital View Page

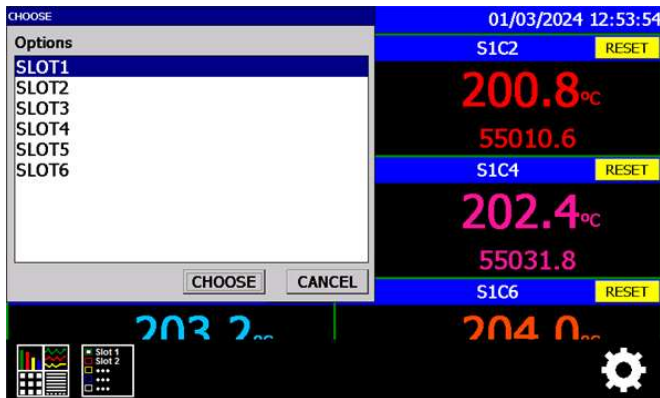

Slot Selection Key is active only in **Digital** and **Bar** view. Process values, totalizer values and alarm conditions can be monitored by selecting the desired slot. Options section on the slot selection screen Number of Channels according to the parameter. Relay card installed or can be listed in slots that are left empty. This empty or relay virtual channels for channels contained in slots with cards can be defined. Slots according to the Number of Channels parameter are listed according to the table below.

SLOT	Channel Number
1	1, 2, 3, 4, 5, 6
2	7, 8, 9, 10, 11, 12
3	13, 14, 15, 16, 17, 18
4	19, 20, 21, 22, 23, 24
5	25, 26, 27, 28, 29, 30
6	31, 32, 33, 34, 35, 36

2.3. Bar View Page



Bar graphs, process values and alarm conditions of 6 channels of the selected slot can be monitored. The slot to be monitored can be selected from the **Slot Selection Key** at the bottom or by scrolling the screen to the right or left.

2.4. Overview Page

E-690		I/O		01/03/2024 13:12:53	
S1C1	S1C2	S1C3	S1C4	S1C5	S1C6
200.0 °C	200.8 °C	201.6 °C	202.4 °C	203.2 °C	204.0 °C
S2C1	S2C2	S2C3	S2C4	S2C5	S2C6
200.0 °C	200.8 °C	201.6 °C	202.4 °C	203.2 °C	204.0 °C
S3C1	S3C2	S3C3	S3C4	S3C5	S3C6
200.0 °C	200.8 °C	201.6 °C	202.4 °C	203.2 °C	204.0 °C
S4C1	S4C2	S4C3	S4C4	S4C5	S4C6
200.0 °C	200.8 °C	201.6 °C	202.4 °C	203.2 °C	204.0 °C
S5C1	S5C2	S5C3	S5C4	S5C5	S5C6
200.0 °C	200.8 °C	201.6 °C	202.4 °C	203.2 °C	204.0 °C
S6C1	S6C2	S6C3	S6C4	S6C5	S6C6
200.0 °C	200.8 °C	201.6 °C	202.4 °C	203.2 °C	204.0 °C

Process values and alarm conditions of all channels defined in the device can be monitored on the **Overview Page**. The amount of channels to be displayed on this page is determined according to the Number of Channels parameter.

3. Menu Pages
3.1. Configuration

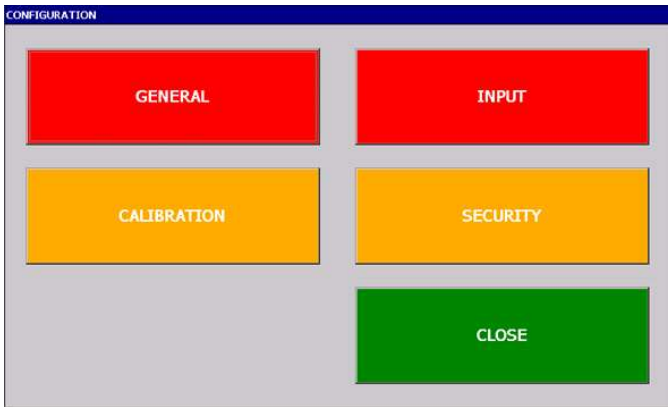

Access to the configuration page is provided with a password. When the login key to the configuration page is pressed, the password window opens. To enter password, touch the yellow part on the password screen. Enter the password from the keyboard screen and press the **OKEY** button. The factory value of the password is **10**.

3.2. General Configuration Page
3.2.1. Device Page

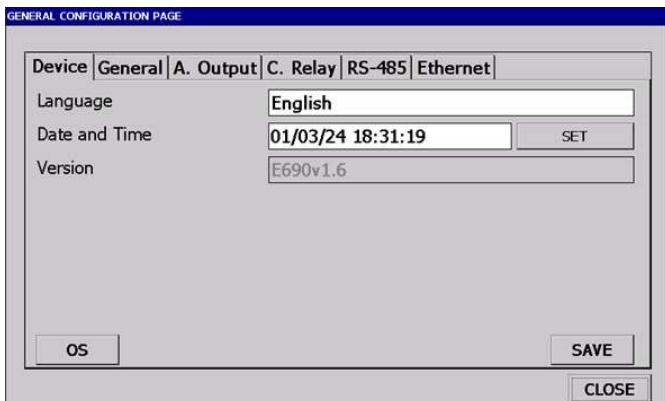

Language (Türkçe / English) : The language of the device.

Date and Time: To set the date and time, press the **SET** button and set it on the screen that opens.

Version : The program version of device is showed.

3.2. General Configuration Page

3.2.1. Device Page

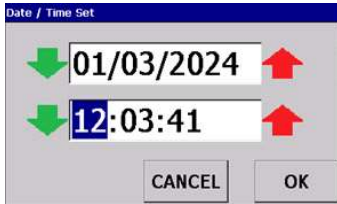

When the **SET** button is pressed on the device page, use the arrows in the window that opens Date and Time can be set.

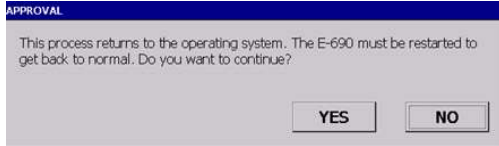

The **OS** key returns to the operating system. Pressing this key opens the **APPROVAL** screen. It is not recommended that the user press this key unless otherwise.

3.2.2. General Page

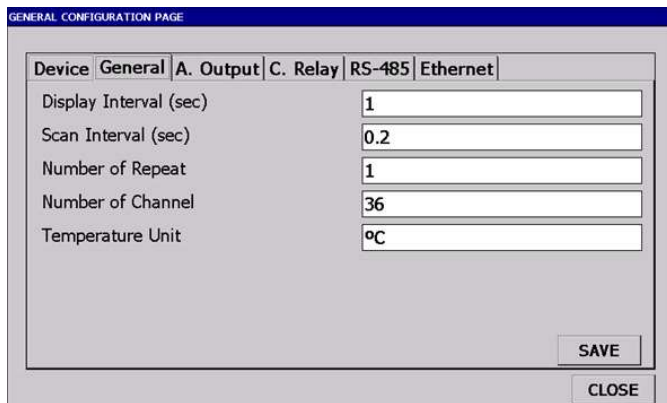

Display Interval (1 - 99 sec) : Channel information display time in automatic mode.

Scan Interval (0.2 - 9.9 sec) : The sampling time of the channels.

Number of Repeat (0 - 12) : Determines how many consecutive scans must pass before an alarm is raised parameter.

Number of Channel (1 - 36) : The total number of the physical and the virtual channels. The virtual channels are used for the results of the arithmetic operation (add, subtract, etc.) on the physical channels.

Temperature Unit (°C / °F) : Indicates the measuring unit of TC and RT inputs. It will be inactive for other inputs. For temperature type inputs, the process value is calculated according to the value of this parameter.

3.2.3. Analog Output Page

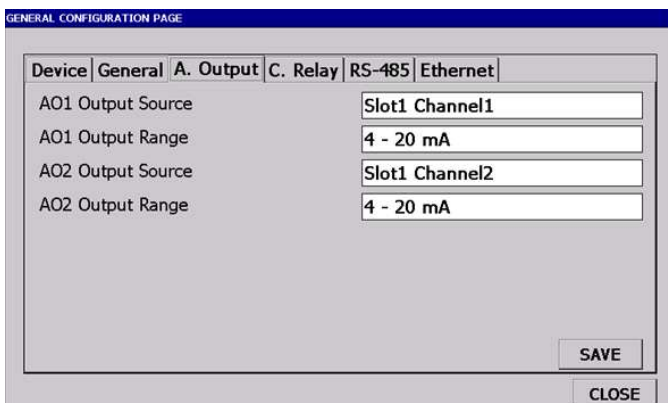

A01 Output Source : Determines the number of the channel to be retransmitted from Analog Output 1.

A01 Output Range : Determines the output range of the Analog Output 1. It can be selected as 0 - 20 mA, 20 - 0 mA, 4 - 20 mA, 20 - 4 mA.

A02 Output Source : Determines the number of the channel to be retransmitted from Analog Output 2.

A02 Output Range : Determines the output range of the Analog Output 2. It can be selected as 0 - 20 mA, 20 - 0 mA, 4 - 20 mA, 20 - 4 mA.

3.2.4. Common Relay Page

GENERAL CONFIGURATION PAGE

Device	General	A. Output	C. Relay	RS-485	Ethernet
Common Relay 1 Control Type		Continuous			
Common Relay 2 Control Type		Continuous			
Pulse Length (sec)		2			
Common Relay 1 Operating Mode		Normally Open			
Common Relay 2 Operating Mode		Normally Open			

SAVE

CLOSE

Common Relay 2 Operating Mode (Normally Open - Normally Closed):

Normally Open: Common relay 2 is energized during an alarm condition and de-energized when there is no alarm.

Normally Closed: Common relay 2 is de-energized during an alarm condition and energized when there is no alarm.

23

Common Relay 1 Control Type (Pulse - Continuous) :

Pulse : After the alarm condition, OR1 relay remains pulled for the **Pulse Length** time.

Continuous : OR1 relay is continuously pulled in case of alarm remains.

Common Relay 2 Control Type (Pulse - Continuous) :

Pulse : After the alarm condition, OR2 relay remains pulled for the **Pulse Length** time.

Continuous : OR2 relay is continuously pulled in case of alarm remains.

Pulse Length (1 - 2 sn) : When **Common Relay Control Type** is selected as Pulse, this parameter determines the relay on time.

Common Relay 1 Operating Mode

(Normally Open - Normally Closed) :

Normally Open: The common relay 1 is energized during an alarm condition and de-energized when there is no alarm.

Normally Closed: The common relay 1 is de-energized during an alarm condition and energized when there is no alarm.

3.2.5. RS-485 Page

GENERAL CONFIGURATION PAGE

Device	General	A. Output	C. Relay	RS-485	Ethernet
Communication Address		1			
Baud Rate		9600			
Parity		None			

SAVE

CLOSE

Communication Address (1 - 31): Sets the communication address for the RS-485 line.

Baud Rate (9600 / 19200 / 38400 / 57600) : Determines the communication speed for the RS-485 line.

Parity (None / Odd / Even) : Specifies the communication parity for the RS-485 line.

24

3.2.6. Ethernet Page

GENERAL CONFIGURATION PAGE

Device	General	A. Output	C. Relay	RS-485	Ethernet
IP Type		Obtain an IP Address via DHCP			
IP Address		10.10.80.6			
Subnet Mask		255.255.255.0			
Default Gateway		10.10.80.1			

SAVE

CLOSE

This is the page where Ethernet settings are configured. **IP type, IP Address, Subnet Mask, and Default Gateway** are selected to set TCP/IP configurations for the Ethernet connection. The IP type can be set to either **Obtain an IP address via DHCP** or **Manual Set**. If the IP type is set to **Obtain an IP address via DHCP**, and there is a DHCP server on the network to which the device is connected, the device can automatically acquire IP settings from this server upon startup. If a static IP address is desired, the IP type should be set to **Manual Set**. On this page, clicking the **SAVE** button saves the values and restarts the device automatically.

25

3.3. Channel Configuration Page

3.3.1. Input Page

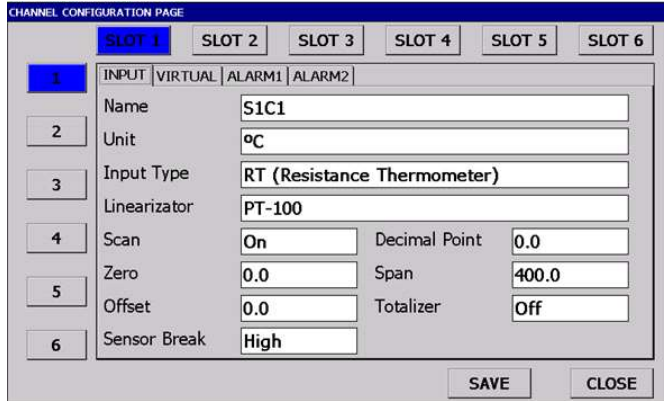

Offset (-32000 / 32000) : Used to correct measurement errors in the sensor. The value specified with this parameter is added to the measurement value.

Name : Maximum 10 characters can be entered.

Determines the channel name.

Unit : Maximum 6 characters can be entered. Process of the channel determines the unit of the value.

Input Type : Specifies the input type of the selected channel. (see Table 2.1)

Linearizer : Determines how the channel will be linearized. (see Table 2.2)

Scan (ON / OFF) :

ON : Channel is open to scanning, **OFF :** Channel off scanning

Decimal Point : This parameter determines the decimal point of measurement value and setpoints. This parameter can be selected as, **0 / No digit**, **0.0 / Single digit**, **0.00 / Two digits**, **0.000 / Three digits after decimal point**.

Zero : Zero value of the linear input type (Milliampere, Millivolt and Volt) . The parameter can be adjusted between -32000 and **SPAN**.

Span : Span value of the linear input type (Milliampere, Millivolt and Volt). The parameter can be adjusted between **ZERO** value and 32000.

3.3.1. Input Page

Totalizer (Off / Minute / Hour) : Off : No totalizer,

Minute : Instantaneous value = unit/minute, **Hour :** Instantaneous value = unit/hour

Sensor Break (Low / High) : Determines the value of the process value in case the sensor is disconnected. When **Low** is selected, the process value is equal to **Zero** value, when **High** is selected, the process value is equal to **Span** value.

The Scan parameter of unused channels should be set to OFF. This reduces the total scan time of the channels. When the input type is changed in the configuration page, the jumpers on the selector board for that channel (**Section 3.8. E-690 Jumper Settings**). Otherwise the reading will be incorrect. A constant measurement error in the sensor If there is an error, the error can be eliminated by giving the appropriate value to the Offset parameter.

Example : If the sensor produces 3°C more than normal, set the Offset parameter to The error can be eliminated by setting it to -3.

Table 2.1

Input Types
TCCJ (Thermocouple compensated.)
TC (Thermocouple uncompensated.)
RT (Resistance Thermometer)
0A20 (0-20 mA)
4A20 (4-20 mA)
0V50 (0-50 mV)
00V1 (0-1 V)
0.2V1 (0.2-1 V)
0V10 (0-10 V)
AvG (Average)

3.3.1. Input Page

Table 2.2

Linearizator	Standard	Measurement Limits	
		(°C)	(°F)
Linear	-	-	-
Square Root	-	-	-
Flow	-	-	-
Flow - Square Root	-	-	-
Type B	IEC 60584-1	60 , 1820	140 , 3308
Type E	IEC 60584-1	-200 , 840	-328 , 1544
Type J	IEC 60584-1	-200 , 1120	-328 , 1562
Type K	IEC 60584-1	-200 , 1360	-328 , 2480
Type L	DIN 43710	-200 , 900	-328 , 1652
Type N	IEC 60584-1	-200 , 1300	-328 , 2372
Type R	IEC 60584-1	-40 , 1760	104 , 3200
Type S	IEC 60584-1	-40 , 1760	104 , 3200
Type T	IEC 60584-1	-200 , 400	-328 , 752
Type U	DIN 43710	-200 , 600	-328 , 1112
PT-100	IEC 60751	-200 , 840	-328 , 1544

If the Linearizer type is selected as Flow-Square Root or Flow, the flow calculation is performed by compensating with the channel measuring pressure given with Channel1 and the channel measuring temperature given with Channel2 on the Virtual page of the input configuration. Coefficient1 is used as the design pressure, and Coefficient2 is used as the design temperature. The only difference between Flow-Square Root and Flow is taking the square root of the input in the former. There is no other difference in terms of calculation. If the input type is selected as Average, the input information for that channel is calculated as follows using the parameters Channel1, Coefficient1, Channel2, Coefficient2, Channel3, Coefficient3, Channel4, Coefficient4:

$$\text{Input Value} = (\text{PV}(\text{Channel1}) \times \text{Coefficient1} + \text{PV}(\text{Channel2}) \times \text{Coefficient2} + \text{PV}(\text{Channel3}) \times \text{Coefficient3} + \text{PV}(\text{Channel4}) \times \text{Coefficient4}) / 100.0$$

(PV(ChannelX)): Process value of Channel X,
CoefficientX: Coefficient of Channel X)

This input is linearized according to the Linearizer parameter like other inputs. To see this input value as process value, the Linearizer parameter is selected as Linear.

3.3.2. Virtual Page

	INPUT	VIRTUAL	ALARM1	ALARM2
1	Channel 1	Slot1 Channel1	Coefficient 1	0.0
2	Channel 2	Slot1 Channel1	Coefficient 2	0.0
3	Channel 3	Slot1 Channel1	Coefficient 3	0.0
4	Channel 4	Slot1 Channel1	Coefficient 4	0.0

Channel X : There are two different ways of use.
 * When Input Type Average is selected, it determines 4 different channels to be used to calculate the virtual channel.
 * When Linearizer Flow or Flow Square Root is selected, Channel 1 is used to select the channel that measures pressure and Channel 2 is used to select the channel that measures temperature.

Coefficient X (-199.9 / 999.9) :
 There are two different ways of use.
 * When Input Type Average is selected, it determines the coefficients of 4 different channels to be used to calculate the virtual channel.
 * When Linearizer Flow or Flow Square Root is selected, Coefficient 1 is used to determine the Design Pressure value and Coefficient 2 is used to determine the Design Temperature values.

Note: The X value used in the Channel and Coefficient descriptions can be 1, 2, 3 or 4.

3.3.3. Alarm1 Page

	INPUT	VIRTUAL	ALARM1	ALARM2
1	Set Point		100.0	
2	Hysteresis		1.0	
3	Alarm Type		No Alarm	
4	Independent Relay		Slot2 Röle1	

Set Point (Zero Value - Span Value): It is the ALARM1 setpoint of the related channel. It can be set between Zero and Span values of the channel.

Hysteresis (-32000 - 32000) : ALARM1 hysteresis value of the related channel.

Alarm Type : Determines the alarm type. It can be selected as follows.

No Alarm : Alarm is canceled.

Lower Alarm (Common Relay) : Alarm activates Common Relay 1.

Upper Alarm (Common Relay) : Alarm activates Common Relay 1.

Lower Alarm (Independent Relay) : Alarm activates the relay selected in Independent Relay.

Upper Alarm (Independent Relay) : The alarm activates the relay selected in the Independent Relay.

Lower Alarm (Common + Independent Relay) : Alarm activates both Common Relay 1 and the relay selected in the Independent Relay.

Upper Alarm (Common + Independent Relay) : Alarm activates both Common Relay 1 and the relay selected in Independent Relay.

Independent Relay : Determines to which independent relay the alarm condition will be forwarded. The alarm of more than one channel can be directed to the same independent relay.

3.3.4. Alarm2 Page

	INPUT	VIRTUAL	ALARM1	ALARM2
1	Set Point			200.0
2	Hysteresis			2.0
3	Alarm Type			No Alarm
4	Independent Relay			Slot2 Röle1

Set Point (Zero Value - Span Value): It is the ALARM2 setpoint of the related channel. It can be set between Zero and Span values of the channel.

Hysteresis (-32000 - 32000) : ALARM2 hysteresis value of the related channel.

Alarm Type : Determines the alarm type. It can be selected as follows.

No Alarm : Alarm is canceled.

Lower Alarm (Common Relay) : Alarm activates Common Relay 2.

Upper Alarm (Common Relay) : Alarm activates Common Relay 2.

Lower Alarm (Independent Relay) : Alarm activates the relay selected in Independent Relay.

Upper Alarm (Independent Relay) : Alarm activates the relay selected in Independent Relay.

Lower Alarm (Common + Independent Relay) : Alarm activates both Common Relay 2 and the relay selected in the Independent Relay.

Upper Alarm (Common + Independent Relay) : The alarm activates both Common Relay 2 and the relay selected in Independent Relay.
Independent Relay : Determines to which independent relay the alarm condition will be directed. Alarms of more than one channel can be directed to the same independent relay.

3.3.5. Alarm Operation Modes

Alarm types and operating modes of E-690 devices are given in the figure below. The parameters related to alarms in the device are Number of Repetitions, Common Role 1 Control Type, Common Relay 2 Control Type, Pulse Length, Set Point for both alarms, Hysteresis, Alarm Type and Independent Relay. According to the Alarm Type parameters for both alarms, they can be directed to common alarm relays or independent alarm relays. If the alarm type is selected OFF, the related alarm is turned off. Which relays the alarms will activate according to the Alarm Type parameter is explained in Alarm Page 1 and Alarm Page 2. Repetition Count is a parameter valid for all defined alarms and determines how many scans will pass before the alarm is given. For example, if the Repetition Count is selected as 3, no alarm will be given at the first detection of the alarm on any channel. If an alarm is detected in at least three consecutive scans, an alarm is set. Common Relay 1 Control Type and Common Relay 2 Control Type are only valid for common alarms and define whether the relevant relay is energized continuously or for the number of seconds in the defined Pulse Length parameter in the event of an alarm. Common Relay 1 Control Type determines the control type of Common Relay 1 and Common Relay 2 Control Type determines the control type of Common Relay 2.

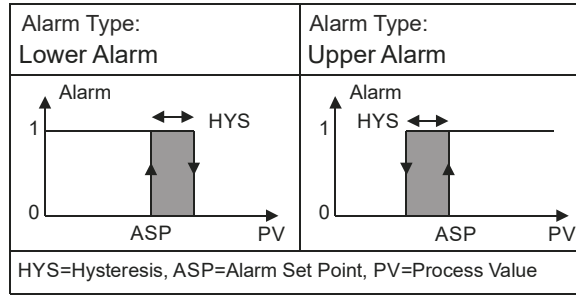

3.4. Calibration Page

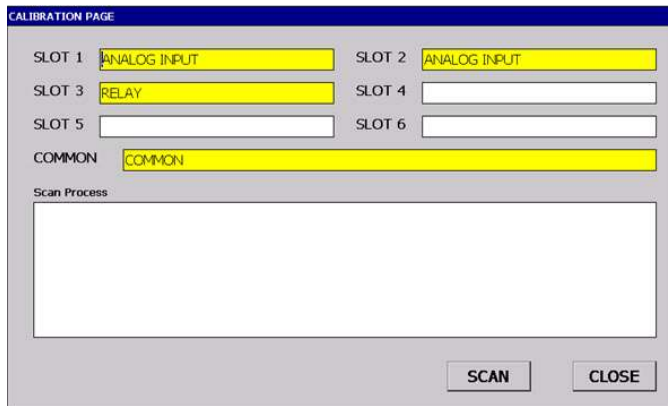

The Calibration Page shows the Analog Input and Relay cards in the device with their slot numbers. During the first use or when a new card is added, the **SCAN** button is pressed to check and list the cards currently connected to the device. Touch the card to be set and the setting page opens.

3.4.1. Analog Input Calibration Page

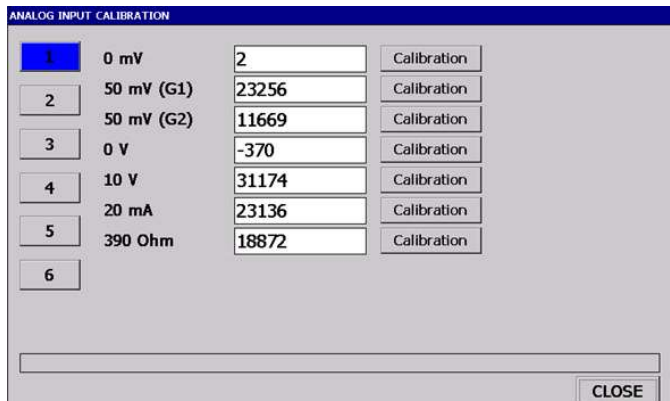

In Analog Input card calibration, after the jumper settings are made according to the desired calibration, the Calibration key of the calibrated parameter is pressed by applying the signals described below to the relevant channel and after the stable value is seen, the value is saved by pressing the same key again. Cancel button cancels the selected calibration.

0 mV: The calibrator is set to the millivolt source position and its output is set to 0.000 mV. The calibrator output is connected to channel 1 of the related card.

50 mV (G1 and G2): The calibrator is switched to the millivolt source position and its output is set to 50.000 mV. The calibrator output is connected to channel 1 of the related card

0 V: The calibrator is set to voltage source and its output is set to 0.00 V. The calibrator output is connected to the related channel.

10 V: The calibrator is switched to the voltage source position and its output is set to 10.00 V. The calibrator output is connected to the related channel.

20 mA: The calibrator is switched to the milliamper source position and its output is set to 20.00 mA. The calibrator output is connected to the related channel.

390 Ohm: The calibrator is switched to the resistance source position and its output is set to 390.00 ohm. The calibrator output is connected to the related channel and make short circuit between negative terminal of channel and 13th terminal of card.

3.4.2. Relay Control Page

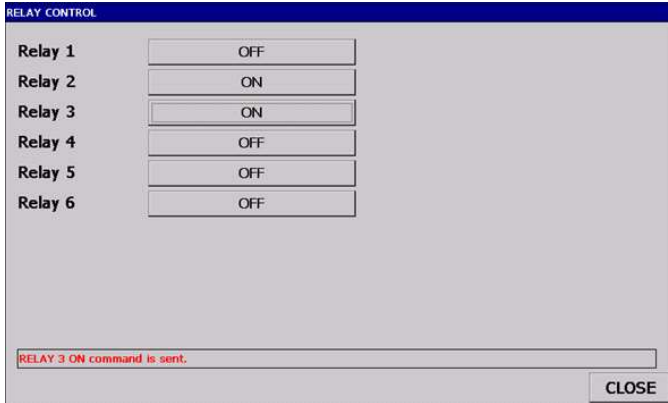

Relay Output Test Page: The status of 6 relays can be changed as ON or OFF on the screen opened in the relay card test. Operation control of relays can be done with this page.

3.4.3. Common Calibration Page

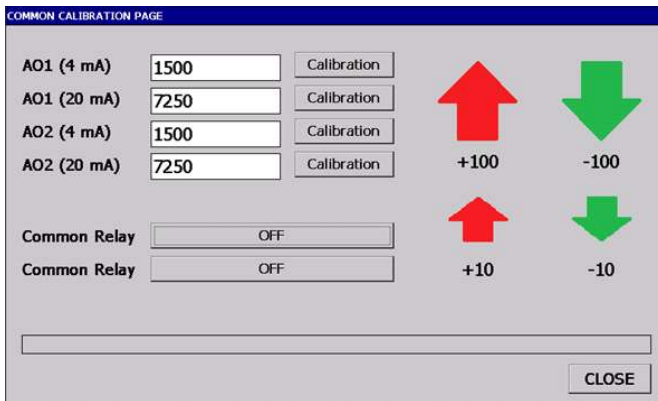

Common Calibration Settings

Calibration for Analog Output 1 or 2 is performed on this page. Before starting the calibration for both outputs, connect an amperemeter to the relevant output. Press the **Calibration** button next to the desired output for calibration. The calibration value can be adjusted using the opened keyboard or the up/down arrows on the side. Once the desired value is reached, press the **Save** button to complete the calibration process.

Additionally, on this page, there are ON/OFF buttons for Common Relay 1 and 2. These buttons can be used to check the operating status of Common Relay 1 and 2.

- AO1(4mA):** Analog Output 1, calibration value at 4 mA.
- AO1(20mA):** Analog Output 1, calibration value at 20 mA.
- AO2(4mA):** Analog Output 2, calibration value at 4 mA.
- AO2(20mA):** Analog Output 2, calibration value at 20 mA.

3.5. Security Configuration Page

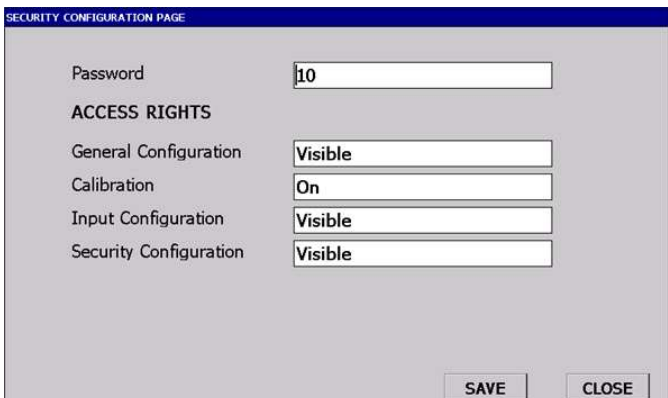

Password (0 - 9999) : It is the password used to access the configuration pages.

General Configuration (Off/Visible/Adjustable) :

If the password is entered incorrectly, the authorization to be given to the user in the General Configuration Page is determined according to this parameter.

Calibration (On / Off) : Calibration pages are shown only when the password is entered correctly. In this case, it determines whether the calibration pages are open to the user or not.

Input Configuration (Off/Visible/Adjustable) :

If the password is entered incorrectly, the authorization to be given to the user on the Login Configuration Page is determined according to this parameter.

Security Configuration (Off/Visible/Adjustable) : If the password is entered incorrectly, the authorization to be given to the user on the Security Configuration Page is determined according to this parameter.

3.6. Warning Messages

In the section where the process value is displayed on the normal operating screens, certain messages may be shown under specific conditions. The meanings of these messages and the necessary actions are explained below.

Message	Description	What to do
OPEN	Sensor break or not connected.	Check sensor and sensor connections.
UFL	Process value is below the sensor type measuring range.	Check sensor and input sensor type.
OFL	Process value is over the sensor type measuring range.	
OFF	The corresponding channel scan parameter is selected OFF	
CERR	Device internal communication failure.	Check the card that failed.

3.7. Connection Diagrams

WARNINGS

- The protective earth cable terminated with the appropriate connection lug must be threaded through the M4 screw head and tightened using the M4 nut.
- This must be done before all electrical connections and the device must remain permanently plugged in during use.
- Do not touch the terminals while the device is energized as there is dangerous voltage on the terminals of the device.
- Before commissioning the device, make sure that the parameters are set according to the intended use. Incorrect configuration may cause damage.
- The POWER CARD must be installed in the POWER CARD SLOT (the slot close to the surface where the grounding screw is located) on the display unit. Inserting in a different slot will cause permanent damage to the device.
- Before energizing the device, the communication connection between the Display Unit and the Input Output Unit must be made. Terminals 4-5-6 on the Indicator Unit must be connected to terminals 1-2-3 on the Input Output Unit power board respectively.



3.7. Connection Diagrams

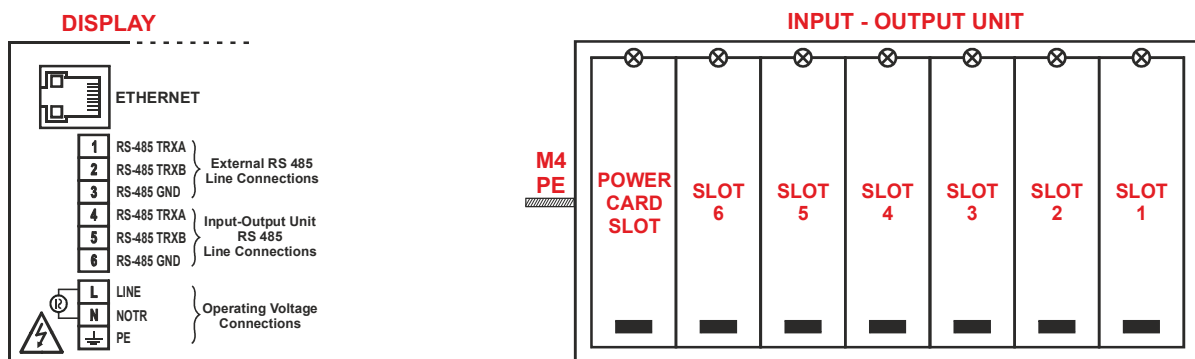

In slots 1-6, one of the following cards is installed or empty depending on the device configuration.

- Analog Input (6 Channels, AIN)
- Relay Output (6 Channel, RELAY)

3.7. Connection Diagrams

Input Output Unit

Power Card Connection Diagram

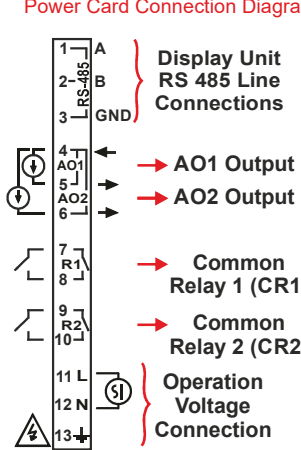

Input Output Unit - Relay, Thermocouple, Millivolt, Volt, Milliampere and RT Connection Diagram

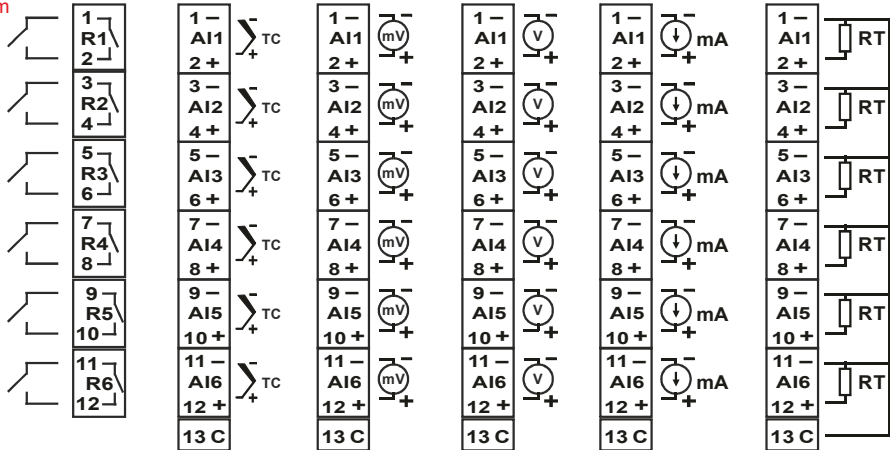

3.8. Jumper Settings

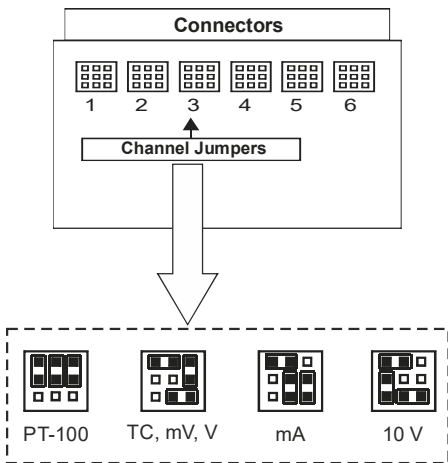

In the E-690, jumper settings for TC (mV, V), RT, mA and 10 V inputs must be set differently. The input to be applied to any channel of the device must be compatible with the Input Type parameter on the **Input Configuration Page** and the jumpers on the input card must be arranged according to this input.

The device has up to 6 Analog Inputs depending on the number of channels. Each analog input card has 6 analog inputs. Jumpers are on the analog input cards. To access the analog input cards, unscrew the screw of the relevant card on the input output unit of the device and remove the card by inserting a small screwdriver into the perforated protrusion at the bottom of the card.

The card on the rightmost part of the INPUT OUTPUT UNIT of the device is SLOT1. As you move to the left, you can find up to SLOT 6 input cards. After the jumper settings of the relevant channel of the card in each SLOT are made, the card is inserted back to the same place. The card is fixed to the device by tightening the screw at the top.

3.9. Communication Connection

A typical communication connection diagram of E-690 devices is given in the figure on the right. The communication connections shown in the figure should be made to the external RS-485 connection terminals on the display unit. As shown in the figure, more than one E-690 can be connected on the same line and the information of all devices can be collected in a center (Computer, PLC). RS-485 is used as communication line. When a computer is used as the center, E-IB-11 (RS-485 / USB converter) should be used because standard computers do not have RS-485 connection. The communication protocol is Modbus. According to this protocol, each device connected to the line must have a different address. The communication addresses of E-690 devices are set with the Communication Address parameter on the RS-485 page. When a computer is used as the center, the communication program must be installed on the computer. The communication program is provided by Elimko Ltd. Sti.

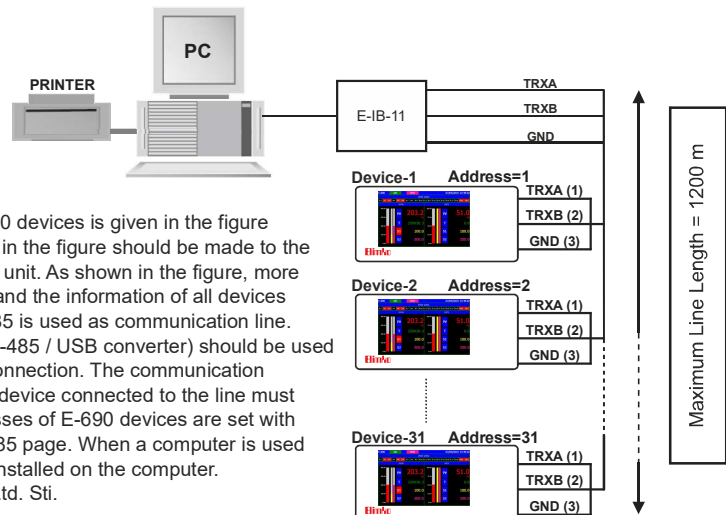

3.9. Communication Connection

Ethernet Connection

RJ45 Pins

Pin Number	Signal
1	TD + (Transmit +)
2	TD - (Transmit -)
3	RD + (Recieve +)
4	Not used
5	Not used
6	RD - (Recieve -)
7	Not used
8	Not used

The E-690 can be connected to ethernet networks via a standard 10/100 MBit ethernet port. Standard TCP/IP is used as the communication protocol.

Network Connection with Ethernet:

Ethernet connection is made with the RJ 45 socket on the rear panel of the device. The device can be connected directly to a computer or a network hub. Crossover cable should be used when connecting the device directly to a computer. When connecting to the hub, it is recommended that the cable is straight. The pin numbers of the RJ45 socket are given in the adjacent figure.

NOTE: The maximum cable length is 100 meters. If it is necessary to use a longer cable between devices, signal strength should be supported with repeaters and gateways.

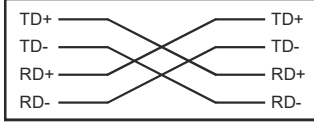

RJ45 pin numbers and Crossover cable connection

EU DIRECTIVE COMPLIANCE



Low Voltage Directive
EN 61010-1

EMC Directive
EN 61326-1



TS EN ISO 9001
Quality Management System Certificate

KY-690-0224-1